

Volume IX: Quarter Turn Valve Automation

Industrial Technical
Manual Series

THIRD EDITION

IPEX QUARTER TURN AUTOMATION

- Pneumatic Actuation
- Electric Actuation
- Accessories



IPEX

Quarter Turn Automation

Industrial Technical Manual Series

Vol. IX, 3rd Edition

© 2008 by IPEX. All rights reserved. No part of this book may be used or reproduced in any manner whatsoever without prior written permission. For information contact: IPEX, Marketing, 2441 Royal Windsor Drive, Mississauga, Ontario, Canada, L5J 4C7.

The information contained here within is based on current information and product design at the time of publication and is subject to change without notification. IPEX does not guarantee or warranty the accuracy, suitability for particular applications, or results to be obtained therefrom.

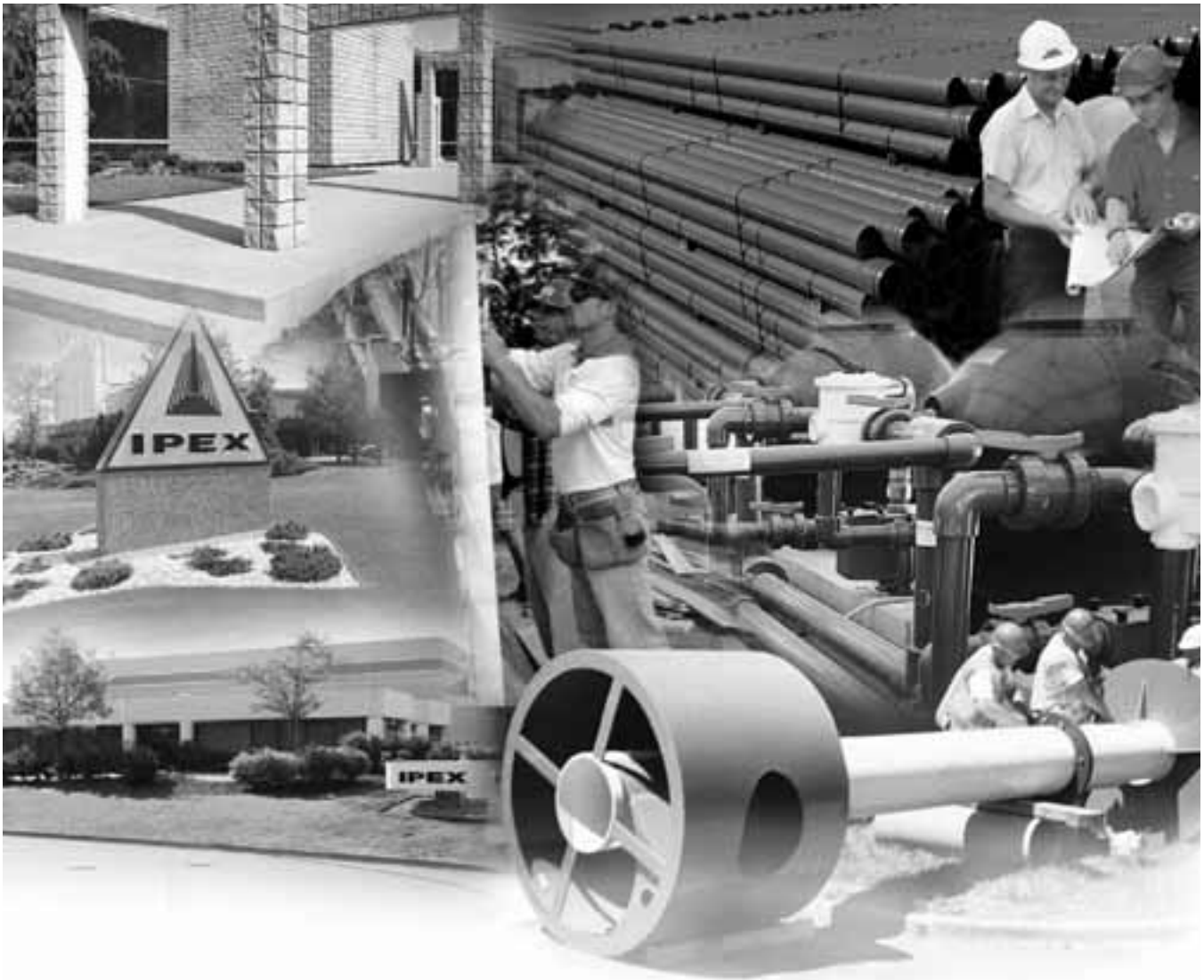

ABOUT IPEX

At IPEX, we have been manufacturing non-metallic pipe and fittings since 1951. We formulate our own compounds and maintain strict quality control during production. Our products are made available for customers thanks to a network of regional stocking locations throughout North America. We offer a wide variety of systems including complete lines of piping, fittings, valves and custom-fabricated items.

More importantly, we are committed to meeting our customers' needs. As a leader in the plastic piping industry, IPEX continually develops new products, modernizes manufacturing facilities and acquires innovative process technology. In addition, our staff take pride in their work, making available to customers their extensive thermoplastic knowledge and field experience. IPEX personnel are committed to improving the safety, reliability and performance of thermoplastic materials. We are involved in several standards committees and are members of and/or comply with the organizations listed on this page.

For specific details about any IPEX product, contact our customer service department.

Engineered thermoplastics are safe inert materials that do not pose any significant safety or environmental hazards during handling or installation. However, improper installation or use can result in personal injury and/or property damage. It is important to be aware of and recognize safety alert messages as they appear in this manual.

The types of safety alert messages are described below.



This safety alert symbol indicates important safety messages in this manual. When you see this symbol be alert to the possibility of personal injury and carefully read and fully understand the message that follows.

WARNING

“WARNING” identifies hazards or unsafe practices that can result in severe personal injury or death if instructions, including recommended precautions, are not followed.

CAUTION

“CAUTION” identifies hazards or unsafe practices that can result in minor personal injury or product or property damage if instructions, including recommended precautions, are not followed.

Note: The use of the word “NOTE” signifies special instructions which are important but are not related to hazards.

For the materials described in this manual, the following warning applies.



WARNING



- **NEVER** use compressed air or gas in PVC/CPVC/PP/PVDF pipe and fittings.
- **NEVER** test PVC/CPVC/PP/PVDF pipe and fittings with compressed air or gas, or air-over-water boosters.
- **ONLY** use PVC/CPVC/PP/PVDF pipe for water and approved chemicals.

Use of compressed air or gas in PVC/CPVC/PP/PVDF pipe and fittings can result in explosive failures and cause severe injury or death.

This page intentionally
left blank

CONTENTS

	Quarter Turn Automation Manual	
	About IPEX	
	Safety Alerts	<i>i</i>
Section One:	Introduction to Quarter Turn Automation	
	General Information	1
Section Two:	Pneumatic Actuators	
	Overview	3
	Features	4
	Operation Guide	5
Section Three:	Electric Actuators	
	Overview	7
	Features	8
Section Four:	Ball Valve	
	VKD Series Ball Valves	9
	VX Series Ball Valves	21
	TKD Series Ball Valves	31
Section Five:	Butterfly Valve	
	FK Series Butterfly Valves	43
	FE Series Butterfly Valves	55
Section Six:	Accessories	
	Solenoid	67
	Speed Control	68
	Exhaust Filter	68
	Limit Switch Box	68
	SPDT Mechanical Switches	69
	Inductive Proximity Sensors	69
	Positioners	70
Section Seven:	Standards	
	Overview	73

This page intentionally
left blank

SECTION ONE: INTRODUCTION TO QUARTER TURN AUTOMATION

GENERAL INFORMATION

More and more industrial processes are turning to automation both as a way of reducing cost and increasing capabilities. Automation allows an operator to control a near infinite number of valves/functions with speed and precision, from a centralized remote location. With increased software sophistication, entire systems can be operated and monitored by a central management system. The popularity of valve automation continues to increase; therefore, focus and understanding of these products is essential to our industry. From simple 'on/off' to complex 'metering' functions, the choices are almost limitless.

A quarter turn valve is any kind of valve that will travel from the fully open to the fully closed position in a 90° motion. Ball, butterfly and certain diverting/multi-port valves fall under this description. Ball and butterfly valves are two of the most commonly used valves in pipelines and feature large flow rates and quick on/off operation.

Without a power source the actuator itself is inadequate. Something needs to 'drive' the actuator so that it can cycle the valve. Two inexpensive, readily available, and easy to transport power options are compressed air (or hydraulic fluid), or electricity. The decision of which to use is determined by the cost of the unit (actuated valve), cost (or availability) of the power supply system, the system layout, performance requirements and operating conditions.

The three basic control functions available through quarter turn automation are:

1. **Double Acting** – This requires external power for each stroke.
For example, power to open the valve, then power to close the valve.
2. **Normally Open** – Also referred to as 'fail safe open',
the default position is open and the actuator requires power to close the valve.
3. **Normally Closed** – Also referred to as 'fail safe closed',
the default position is closed and the actuator requires power to open the valve.



This page intentionally
left blank

SECTION TWO: PNEUMATIC ACTUATORS

OVERVIEW

Pneumatic actuators are the most common choice for quarter turn plastic valves in process applications. Compressed air systems are readily available in any plant, and the cost of the actuator itself is generally lower than that of an electric unit with a comparable torque output. Typical quarter turn automation seldom requires positioning (something achieved more easily with an electric actuator), therefore the cycle life of a pneumatic unit will be substantially greater, and will be intrinsically safer than an electric actuator in volatile environments.

While there are many different kinds of pneumatic actuators, a rack and pinion style is the preferred choice within the plastic piping industry. This type of actuator is quite tough and rugged, and has a high cycle life. They generally have a compact, simple construction, and certain models can be quite light in weight. The design also allows the same basic actuator to be used as a double acting or (with minor additions) a spring return unit.

Spring Return (Air to Spring)

A spring return pneumatic actuator which requires an air stroke to either close or open the valve and contains a spring that forces the valve back to the opposite (default) position.

Normally Closed (Fail Safe Closed)

A spring return actuator mounted on the valve in such a way that at the end of the spring stroke the valve is closed. Air is required to open the valve. This will be the preferred choice if the valve is mostly in the closed position or if, in case of an emergency where the power to the actuator fails, the valve needs to close for safety reasons.

Normally Open (Fail Safe Open)

A spring return actuator mounted on the valve in such a way that at the end of the spring stroke the valve is open. Air is required to close the valve. This will be the preferred choice if the valve is mostly in the open position or if, in case on an emergency where the power to the actuator fails, the valve needs to open for safety reasons.

Double Acting (Air to Air)

A pneumatic actuator with no spring stroke. Air is required to both open and close the valve. In the absence of new input (compressed air) the unit will remain in the previous position (either open or closed).

Control Media

Most pneumatic actuators will also work with a clean, non-clogging hydraulic fluid; however compressed air is generally more readily available. As such, both the cleanliness of the supply air, and corrosion resistance of the internal components will contribute to a long, maintenance free actuator life. Ambient air will also be in contact with many components of an actuator, so selection of suitable corrosion resistant materials (e.g. high strength polymers and stainless/epoxy coated metals) may be necessary.

FEATURES

Depending on size and application actuators may have a Technopolymer or an Aluminum Housing.

Compact Design

Our rack & pinion pneumatic actuator produces linear torque output in a compact design utilizing the same body and end caps for double acting and spring return units.

Corrosion Resistance

Double-Acting or Spring-Return housing are manufactured from a polyamide base material or an anodized aluminum utilizing high cycle life spring cartridges made with non-metallic materials (springs are epoxy coated).

Pre-Loaded Spring Cartridges

Epoxy coated special steel springs are pre-loaded with non-metallic materials. The stainless steel end cap fasteners are extra long to allow for spring relaxation. All parts are corrosion resistant.

Stainless Steel Pinions and Fasteners

All manufactured from high quality stainless steel.

Bottom Mounting Flange

The “patent pending” bottom plate design secures a captive pinion (anti-blowout system) and permits flexibility in mounting by retaining AISI 304 nuts (standard) or AISI 304 bolts (optional) in either dual ISO patterns, or to customer dimensions.

Namur Mounting

Namur VDI/VDE 3845 and ISO 5211 dimensions on all sizes. No special blocks are required to mount solenoid valves, limit switches or positioners.

Blowout Proof Protection

Mechanically held in with our exclusive patent-pending flange design, pinions are 100% blowout proof ensuring safe and effective operation.

ISO 5211 Output Drive

Standard on all pneumatic actuators, the lower pinion comes standard as a double-square female output drive according to the ISO 5211 standard. Optional double-d shafts are available upon request.

Rugged Tooth Design

The pinion teeth are engaged the full length and stroke of the piston. The pinion height allows manual override without disturbing the indicated positions.

Solenoid Connection

Solenoid valve connection according to VDI/VDE 3845 made with an insert in alloy UNI 5076 (ASTM B179) coated with high corrosive resistance material; air connections are 1/4" NPT.

Versatile Operating Media

Air (lubricated if possible), Hydraulic oil or water, minimum of 40psi pressure (1 bar) and maximum of 120psi pressure (8 bar).

Working Temperature

Standard working temperature range of -4°F to 176°F (-20°C to 80°C).

Low temperature with Silicone seals -55°F (-48°C)

High temperature with Viton seals to 250°F (121°C); 300°F (149°C) cyclic

Degree of Travel

The standard angle of rotation is 90°. Additional travel rotations of 120°, 135°, 150° and 180° are available. Larger size aluminum housing actuators feature dual travel stops that provide for ± 10° stroke registration on both the opening and closing phases of the actuator stroke.

Honed Bore for High Cycle Life

Extruded aluminum body is internally machined and lapped to exact specifications. Honing prevents dry spots from forming within the actuator bore and therefore eliminates premature seal failure – a critical aspect to long cycle life. All internal and external surfaces are hard anodized for corrosion resistance, with all units permanently lubricated at the factory with non-silicone grease.

High Cycle Bearings

Shaft bearings isolate the pinion gear from the housing and support the shaft for high cycle applications.

High Visibility Position Indication

External open/close indicator is standard, available for all the rotations.

Traceability

All units are serial number stamped for traceability back to the manufacturing date, time, and personnel.

Quality Assurance

All units are seal tested throughout the cycle of the actuator on highly sensitive electronic equipment.

OPERATION GUIDE

Double Acting Actuators

IPEX actuators have a standard angle of rotation of 90°. Additional travel rotations of 120°, 135°, 150°, and 180° are available. Sizes UT16DA and larger feature dual travel stops that provide for ± 10° stroke registration on both the opening and closing phases of the actuator stroke.

Double Acting

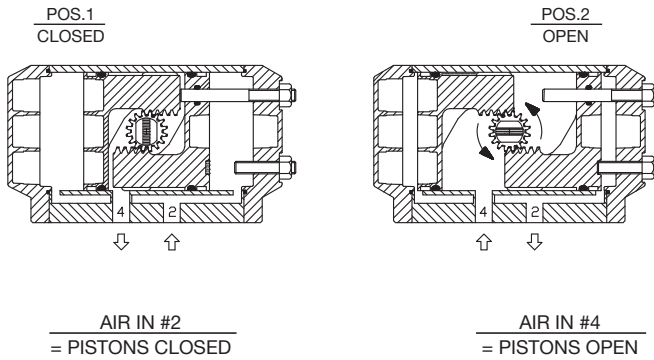

↑ = AIR IN ↓ = AIR OUT

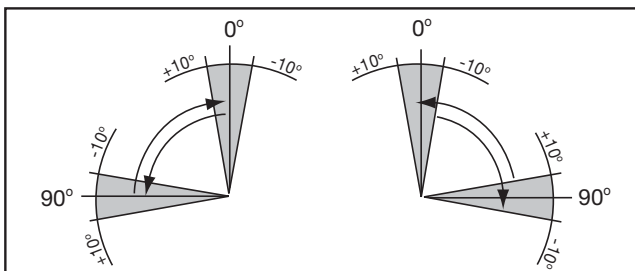

Spring Return Actuator Terminology

1. Air Stroke

When air is supplied to the actuator, the pistons compress the springs. The greater the spring compression, the less torque output the actuator can supply.

2. Spring Stroke

When air is removed from the actuator, the stored energy in the springs forces the pistons inward. At full compression, the spring is at its maximum torque output. This is the Spring Start. When springs are uncompressed, this is the Spring End.

3. Fail Position

IPEX actuators can be preset for fail closed or fail open operation.

Spring Return

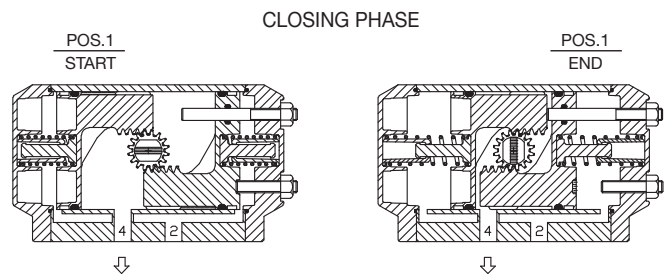
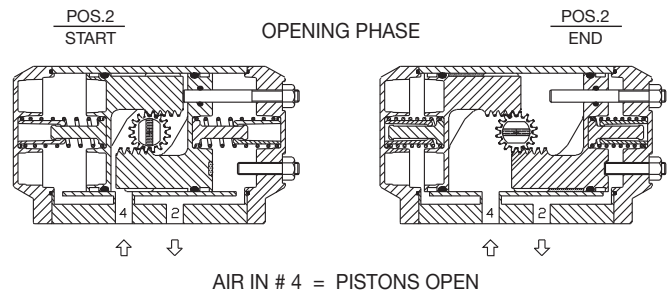

This page intentionally
left blank

SECTION THREE: ELECTRIC ACTUATORS

OVERVIEW

Although slightly more expensive than pneumatics, electric actuators have certain desirable benefits. They are the preferred choice when cycle time is an issue, as a quick closing pneumatically actuated valve could cause a damaging pressure surge condition (water hammer). The use of an electric actuator may also be preferred when the distance from the power source is considerable. The friction losses in long runs of compressed air line may result in reduced efficiency and/or additional compressor stations.

In addition, electric actuators are the preferred (if not the only) choice when a quarter turn valve like a multi-port is used. In this case, it is possible that the travel required is not just 0° to 90° but 0° to 90° to 180°. A rack and pinion actuator would need four separate pistons and a multiplicity of related air chambers, whereas this is easily accomplished with an electric unit.

Most electric actuators have a cam/limit switch arrangement which allows the unit to be set up for a variety of rotations. The two standard limit switches can be used to provide a remote location with an open or closed signal. A multitude of voltages both for AC and DC current are also typically available.

IP Rating

IP stands for 'Ingress Protection'. An IP number is used to specify the environmental protection of enclosures around electronic equipment. These ratings are determined by specific tests. The IP number is composed of two numbers, the first referring to the protection against solid objects and the second against liquids. The higher the number, the better the protection.

Nema Rating

Electric actuators are often supplied with a NEMA 4 or equivalent rated enclosure. This allows the use of the actuated valve in outdoor applications. More demanding environments may require a greater rating (e.g. 4X for corrosion proof, 7 for explosion proof, etc.)

Declutchable Manual Override

Most electric units will have a way to manually rotate the actuator's shaft (thus opening or closing the valve). Depending on the size of the actuator, this may be a very difficult if not impossible operation. A declutchable override will allow the manual operation of the valve without having to fight the resistance of the actuator's winding.

Reversible

A reversible actuator will travel in one direction (e.g. clockwise) to open (or close), and then will reverse its direction of travel to reach the opposite function. Although more expensive than unidirectional units, reversible actuators are preferable. Reversing the travel will wear the valve seat in an even way resulting in much greater cycle life of the actuated valve.

Cycle Time

The travel time that an electric actuator employs from beginning to end of a 90° rotation.

Duty Cycle

The percentage of time that an electric actuator can be energized versus the time it needs to be de-energized. Exceeding the actuator cycle time will result in the failure of the unit due to over-heating. Many units have a standard duty cycle of 25% while others may be as great as 75%.

Standard Features

Enclosure

Enclosures are made of a V0 self-extinguishing class corrosion-resistant techno-polymer and are IP 67 rated. IP 67 enclosures have complete protection against dust and are protected against the effects of immersion (in water) between 6" and 39". IP 67 ratings are equivalent to NEMA 6 ratings.

Position Indicator

Actuators have external visual position indicators.

Permanent Lubrication

Bushings are self-lubricated, reducing the need for maintenance.

Heavy Duty Gears

Steel and techno-polymer gear wheels with hardened steel pinions help withstand stall conditions and reduce down time due to gear failure.

Universal Mounting

Actuators can be mounted and operated in any position with ISO 5211 double star mounting.

Adjustability

Actuators automatically adjust motor speed and output torque, depending on process variations, to keep cycle times consistent.

Optional Features

Electronic Positioner

For precise control applications that use analog signals (4-20mA, 0-10VDC).

Heater

The heater is activated once the actuator is powered and when the temperature inside the housing falls below 77°F.

Limit Switches

2 SPDT limit switches allow for independent fine tuning of the open and closed positions.

Declutchable Manual Override

Allows the valve to be cycled 'on' or 'off' during a power failure, without having to overcome the resistance of the actuator's winding.

Holding Power

Actuators are able to hold 150% of the rated torque, in either direction, while power is removed from the control.

Duty Cycle

Actuators have a 75% duty cycle, allowing for high cycle applications.

Torque Limiter

Will shut the actuator off in stall conditions to protect the motor.

Battery Back Up

Cycles valve to a fail safe position if a power failure occurs.

SECTION FOUR: BALL VALVES

VKD SERIES BALL VALVES

IPEX VKD Series Automated Ball Valves offer a variety of advanced features such as the patented seat stop carrier, a high quality stem and ball support system, and the new DUAL BLOCK® system which locks the union nuts, preventing back-off due to vibration or thermal cycling. Deep grooves, thick o-rings, and cushioned Teflon® seats contribute to strong seals at pressures up to 232psi while an integral mounting flange and support bracketing combine for simple adaptation for actuation and anchoring. VKD Series Automated Ball Valves are part of our complete systems of pipe, valves, and fittings, engineered and manufactured to our strict quality, performance, and dimensional standards.

Standards



ASTM D1784
ASTM D2464
ASTM D2466
ASTM D2467
ASTM D4101
ASTM F1498
ASTM F437
ASTM F439



ANSI B1.20.1



ISO 11922-1

Valve Availability

Body Material	PVC, CPVC, PP, ABS
Size Range	1/2" through 4"
Pressure	232psi, 150psi (PP)
Seats	Teflon® (PTFE)
Seals	EPDM or Viton® (FKM)
End Connections	Socket (IPS), Threaded (FNPT), Socket (Metric)
Actuator Control	Double Acting Pneumatic, Spring Return Pneumatic, Electric



VKD SERIES BALL VALVES

Sample Specification

1.0 Ball Valves – VKD

1.1 Material

- The valve body, stem, ball and unions shall be made of PVC compound which shall meet or exceed the requirements of cell classification 12454 according to ASTM D1784.
- or The valve body, stem, ball and unions shall be made of Corzan® CPVC compound which shall meet or exceed the requirements of cell classification 23447 according to ASTM D1784.
- or The valve body, stem, ball and unions shall be made of stabilized PP homo-polymer compound, also containing a RAL 7032 pigment, which shall meet or exceed the requirements of Type I Polypropylene according to ASTM D4101.
- or The valve body, stem, ball and unions shall be made of Duraplus® ABS compound, which shall meet or exceed the requirements of cell classification 43234 according to ASTM D3965.

1.2 Seats

- The ball seats shall be made of Teflon® (PTFE).

1.3 Seals

- The o-ring seals shall be made of EPDM.
- or The o-ring seals shall be made of Viton® (FKM).

1.4 All other wetted parts of the valves shall comply with standards that are equivalent to NSF Standard 61 for potable water.

2.0 Connections

2.1 Socket style

- The IPS socket PVC end connectors shall conform to the dimensional standards ASTM D2466 and ASTM D2467.
- or The IPS socket CPVC end connectors shall conform to the dimensional standard ASTM F439.
- or The Metric socket PP end connectors shall conform to the dimensional standard ISO 11922-1.

2.2 Threaded style

- The female NPT threaded PVC end connectors shall conform to the dimensional standards ASTM D2464, ASTM F1498 and ANSI B1.20.1.
- or The female NPT threaded CPVC end connectors shall conform to the dimensional standards ASTM F437, ASTM F1498 and ANSI B1.20.1.
- or The female NPT threaded PP end connectors shall conform to the dimensional standards ASTM F1498 and ANSI B1.20.1.

3.0 Design Features

- The valve shall be double blocking with union ends.
- All valves shall be full port.
- All valves shall allow for bi-directional flow.
- The valve body shall be single end entry with a threaded carrier (ball seat support).

- The threaded carrier shall be adjustable with the valve installed.
- The valve body shall have an expansion and contraction compensating groove on the molded end.
- The valve body, union nuts and carrier shall have deep square style threads for increased strength.
- The ball and stem shall be machined smooth to minimize wear on valve seats and seals.
- All valve seats shall have o-ring backing cushions to compensate for wear and prevent seizure of the ball.
- The stem design shall feature double o-ring seals as well as a safety shear point above the o-rings.
- All valves shall have integrally molded mounting features for actuation.
- All valves shall have integrally molded support bracketing for anchoring.
- The valve shall include the Dual Block® union nut locking mechanism.

3.1 Pressure Testing

- All valves shall have been pressure tested in both the open and closed positions by the manufacturer.

3.2 Pressure Rating

- All PVC, CPVC and ABS valves shall be rated at 232psi at 73°F.
- All PP valves shall be rated at 150psi at 73°F.

3.3 Markings

- All valves shall be marked to indicate size, material designation, and manufacturer's name or trade mark.

3.4 Color Coding

- All PVC valves shall be color-coded dark gray.
- or All CPVC valves shall be color-coded light gray.
- or All PP valves shall be color coded beige gray.
- or All ABS valves shall be color coded light gray.

4.0 All valves shall be Xirtec® 140, Corzan®, SFPP or Duraplus® by IPEX or approved equal.

5.0 Actuators

- All actuators shall be factory installed by IPEX.
- Pneumatic actuators shall be dual piston rack and pinion design, sized for 80psi control air pressure.
- Electric actuators shall have 110 VAC reversing motors, torque limiters, thermal protection and NEMA 4 or equivalent housings.

VKD SERIES BALL VALVES

Dimensions

Sizes: 1/2" – 2"

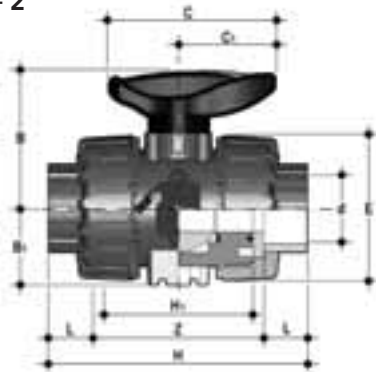

Sizes: 2-1/2" – 4"

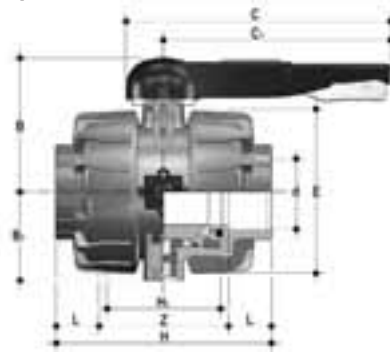

DIMENSIONS (inches)

Size	d	L	Z	H	H1	E	B1	B	C1	C
1/2	0.84	0.89	2.83	4.61	2.56	2.13	1.14	2.13	1.57	2.64
3/4	1.05	1.00	3.07	5.08	2.76	2.56	1.36	2.56	1.93	3.35
1	1.32	1.13	3.33	5.59	3.07	2.87	1.54	2.74	1.93	3.35
1-1/4	1.66	1.26	3.86	6.38	3.46	3.39	1.81	3.25	2.52	4.25
1-1/2	1.90	1.38	4.02	6.77	3.66	3.86	2.05	3.50	2.52	4.25
2	2.38	1.50	4.83	7.83	4.37	4.80	2.44	4.25	2.99	5.28
2-1/2	2.88	1.75	5.75	9.25	5.24	6.46	3.43	6.46	6.89	8.86
3	3.50	1.89	6.85	10.63	5.87	7.99	4.13	6.97	10.71	12.87
4	4.50	2.26	7.60	12.13	6.57	9.37	5.08	7.80	12.99	15.16

Sizes: 1/2" – 2"

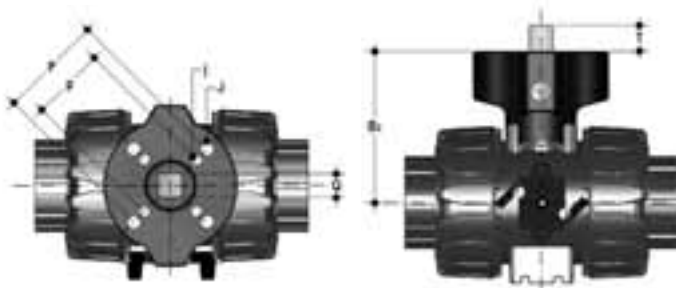

Sizes: 2-1/2" – 4"

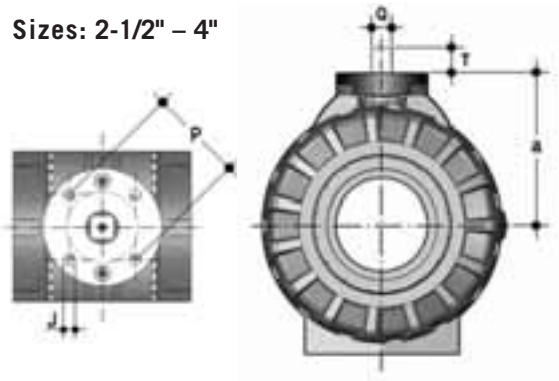

DIMENSIONS (inches)

Size	a	T	Q	p / P	j / J
1/2	2.28	0.47	0.43	F03 / F04	0.22
3/4	2.89	0.47	0.43	F03 / F05 or F04	0.22 / 0.26 or 0.22
1	2.91	0.47	0.43	F03 / F05 or F04	0.22 / 0.26 or 0.22
1-1/4	3.82	0.63	0.43 or 0.55	F05	0.26
1-1/2	4.09	0.63	0.43 or 0.55	F05	0.26
2	4.49	0.63	0.43 or 0.55	F05 / F07	0.26 / 0.33
2-1/2	4.69	0.63	0.55	F07	-
3	5.20	0.63	0.55	F07	-
4	5.91	0.75	0.67	F07	-

VKD SERIES BALL VALVES

Models UT11, UT14, UT19

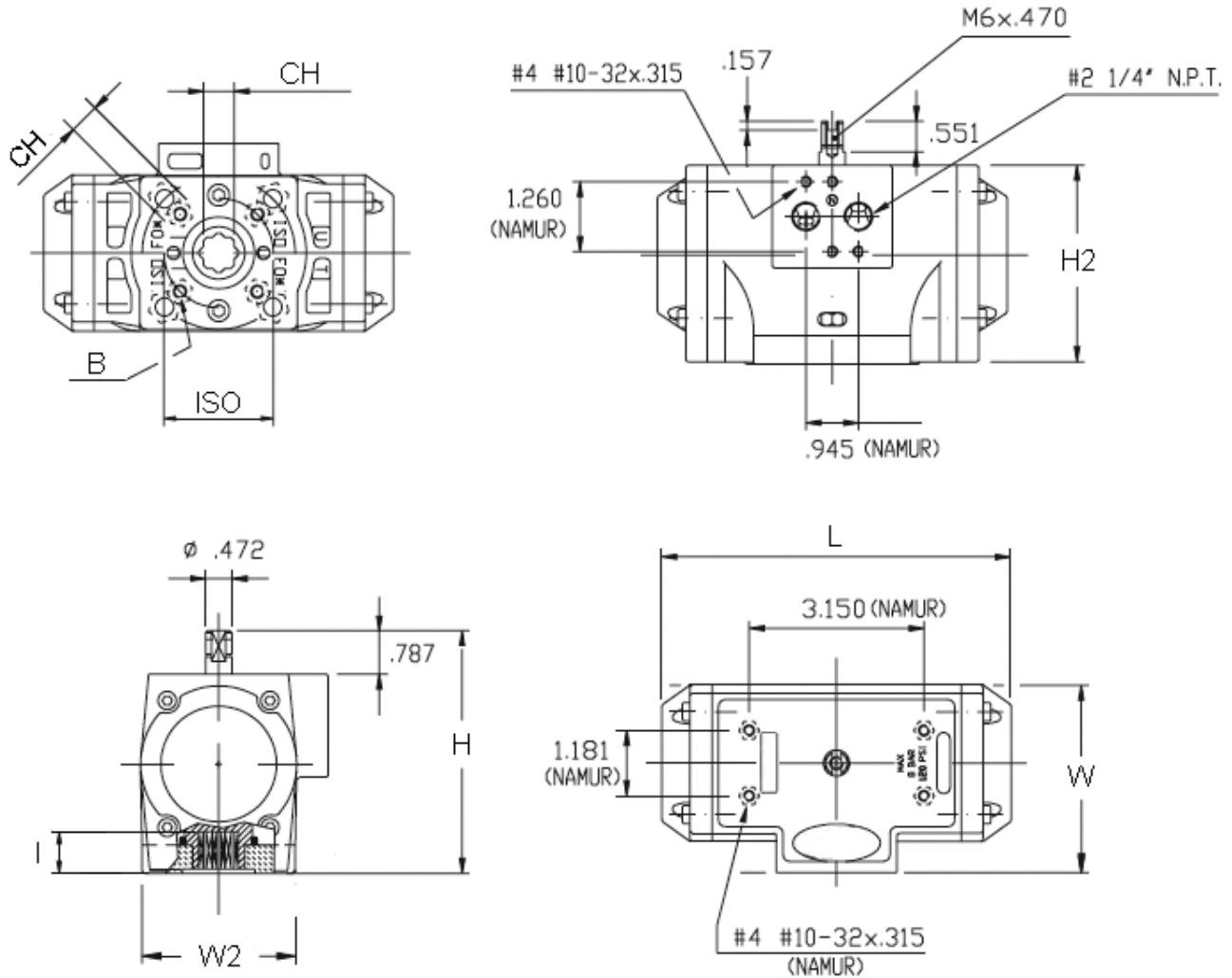

BALL VALVES

DIMENSIONS (inches)

Valve Size	Double Acting Model	ISO	CH	L	W	W2	H	H2	I	B
1/2	UT11DA	F04	0.43	4.69	2.64	2.09	3.58	2.76	0.49	10-32 UNF x 0.40
3/4	UT11DA	F04	0.43	4.69	2.64	2.09	3.58	2.76	0.49	10-32 UNF x 0.40
1	UT11DA	F04	0.43	4.69	2.64	2.09	3.58	2.76	0.49	10-32 UNF x 0.40
1-1/4	UT14DA	F05 / F07	0.55	6.30	3.39	2.76	4.37	3.54	0.75	1/4-20 UNC x 0.51
1-1/2	UT14DA	F05 / F07	0.55	6.30	3.39	2.76	4.37	3.54	0.75	1/4-20 UNC x 0.51
2	UT14DA	F05 / F07	0.55	6.30	3.39	2.76	4.37	3.54	0.75	1/4-20 UNC x 0.51
2-1/2	UT19DA	F05 / F07	0.67	6.89	3.98	2.76	5.22	4.39	0.91	5/16-18 UNC x 0.51
3	UT19DA	F05 / F07	0.67	6.89	3.98	2.76	5.22	4.39	0.91	5/16-18 UNC x 0.51
4	UT26DA	F05 / F07	0.67	9.41	3.78	3.39	5.63	4.41	0.91	5/16-18 UNC x 0.51

VKD SERIES BALL VALVES

Models UT26, UT31, UT36

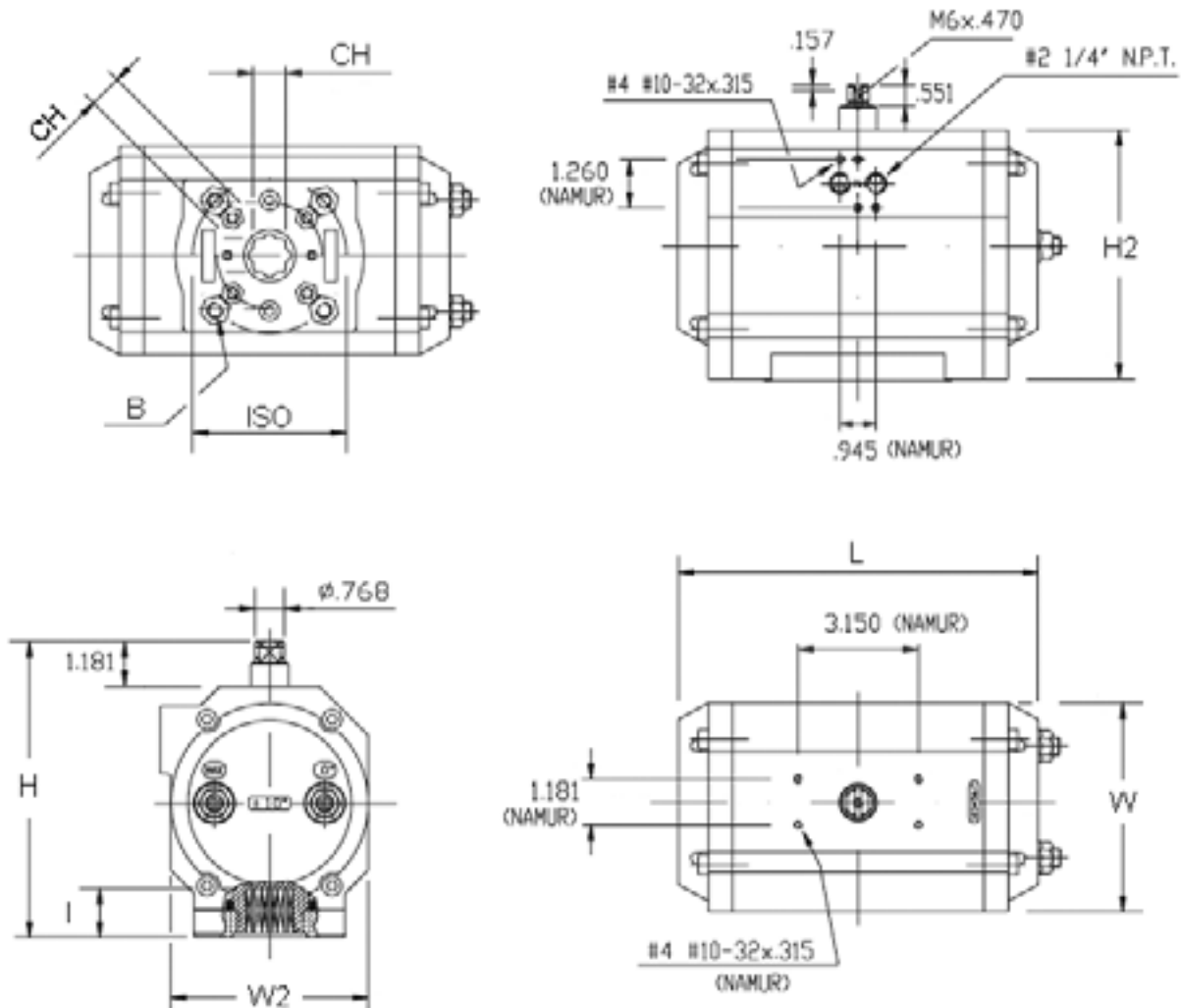

DIMENSIONS (inches)

Valve Size	Spring Return Model	ISO	CH	L	W	W2	H	H2	I	B
1/2	UT11S2	F04	0.43	4.69	2.64	2.09	3.58	2.76	0.49	10-32 UNF x 0.40
3/4	UT11S2	F04	0.43	4.69	2.64	2.09	3.58	2.76	0.49	10-32 UNF x 0.40
1	UT14S4	F05 / F07	0.55	6.30	3.39	2.76	4.37	3.54	0.75	1/4-20 UNC x 0.51
1-1/4	UT14S4	F05 / F07	0.55	6.30	3.39	2.76	4.37	3.54	0.75	1/4-20 UNC x 0.51
1-1/2	UT19S5	F05 / F07	0.67	6.89	3.98	2.76	5.22	4.39	0.91	5/16-18 UNC x 0.51
2	UT19S5	F05 / F07	0.67	6.89	3.98	2.76	5.22	4.39	0.91	5/16-18 UNC x 0.51
2-1/2	UT31S4	F05 / F07	0.67	9.06	4.45	4.09	6.38	5.16	0.91	5/16-18 UNC x 0.51
3	UT31S4	F05 / F07	0.67	9.06	4.45	4.09	6.38	5.16	0.91	5/16-18 UNC x 0.51
4	UT36S4	F05 / F07	0.87	9.69	5.43	5.16	7.72	6.50	1.18	3/8-16 UNC x 0.71

VKD SERIES BALL VALVES

Electric Actuator Dimensions

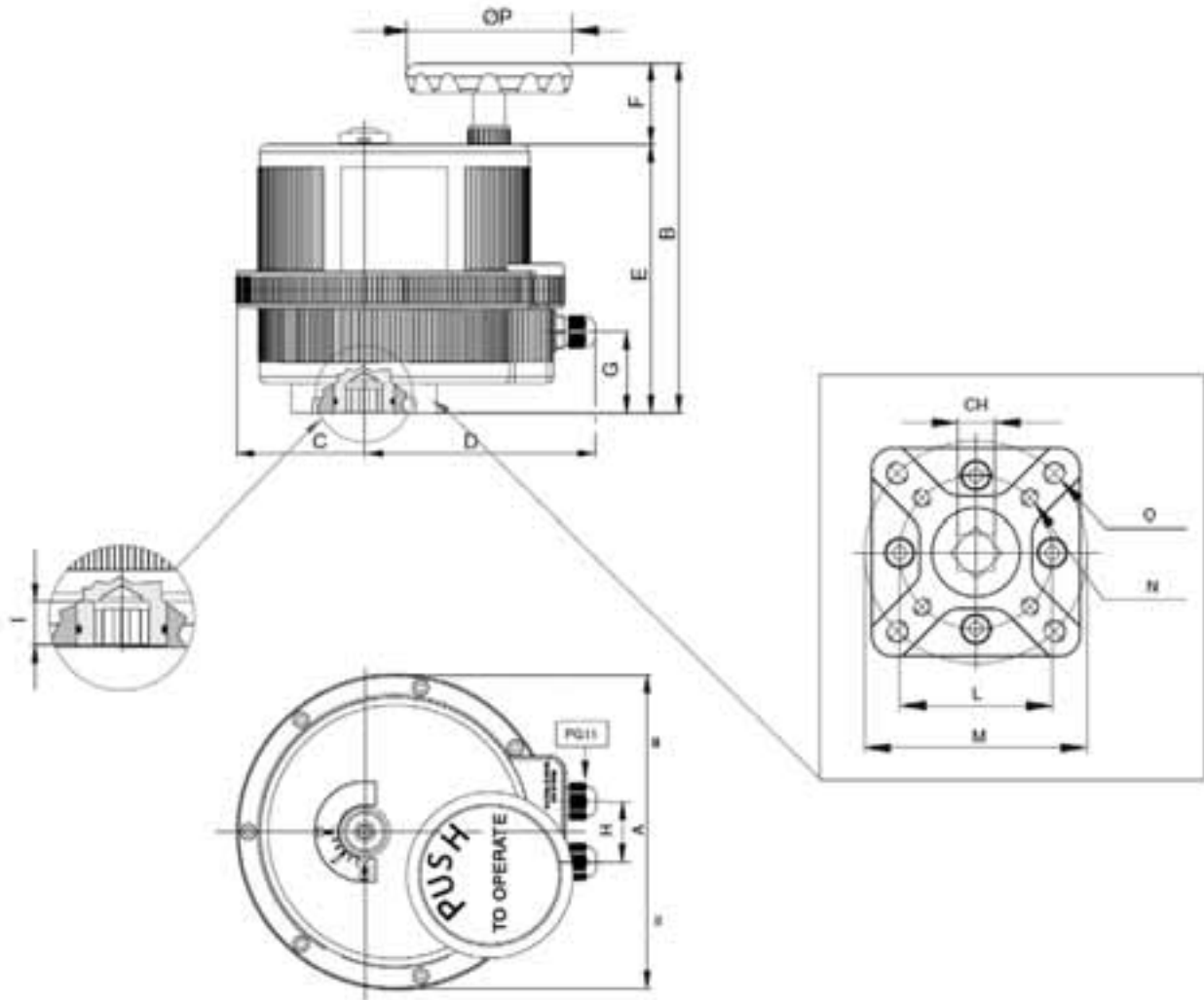

DIMENSIONS (inches)

Valve Size	Actuator Model	ISO	CH	A	B	C	D	E	F	G	H	I	L	M	N	O
1/2	VB015	F03 / F05	0.43	4.84	6.28	1.67	4.78	5.67	0.61	4.35	1.26	0.47	1.42	1.97	10-24 UNC x 0.55	1/4-20 UNC x 0.55
3/4	VB015	F03 / F05	0.43	4.84	6.28	1.67	4.78	5.67	0.61	4.35	1.26	0.47	1.42	1.97	10-24 UNC x 0.55	1/4-20 UNC x 0.55
1	VB015	F03 / F05	0.43	4.84	6.28	1.67	4.78	5.67	0.61	4.35	1.26	0.47	1.42	1.97	10-24 UNC x 0.55	1/4-20 UNC x 0.55
1-1/4	VB015	F03 / F05	0.43	4.84	6.28	1.67	4.78	5.67	0.61	4.35	1.26	0.47	1.42	1.97	10-24 UNC x 0.55	1/4-20 UNC x 0.55
1-1/2	VB030	F03 / F05	0.43	6.18	7.39	2.38	5.01	5.75	1.64	1.30	1.42	0.47	1.42	1.97	10-24 UNC x 0.55	1/4-20 UNC x 0.55
2	VB030	F03 / F05	0.43	6.18	7.39	2.38	5.01	5.75	1.64	1.30	1.42	0.47	1.42	1.97	10-24 UNC x 0.55	1/4-20 UNC x 0.55
2-1/2	VB060	F05 / F07	0.55	7.28	8.46	2.66	5.77	6.81	1.65	2.01	1.42	0.63	1.97	2.76	1/4-20 UNC x 0.67	5/16-18 UNC x 0.67
3	VB060	F05 / F07	0.55	7.28	8.46	2.66	5.77	6.81	1.65	2.01	1.42	0.63	1.97	2.76	1/4-20 UNC x 0.67	5/16-18 UNC x 0.67
4	VB110	F07 / F10	0.67	8.19	9.14	3.31	6.02	7.01	2.13	2.13	1.57	0.75	2.76	4.02	5/16-18 UNC x 0.79	3/8-16 UNC x 0.79

VKD SERIES BALL VALVES



Note: Pneumatic actuator performance is based on 80psi available control air pressure.

Actuator Technical Data

Valve Size (inches)	Double Acting Pneumatic	Spring Return Pneumatic	Electric
1/2	UT11DA	UT11S2	VB015
3/4	UT11DA	UT11S2	VB015
1	UT11DA	UT14S4	VB015
1-1/4	UT14DA	UT14S4	VB015
1-1/2	UT14DA	UT19S5	VB030
2	UT14DA	UT19S5	VB030
2-1/2	UT19DA	UT31S4	VB060
3	UT19DA	UT31S4	VB060
4	UT26DA	UT36S4	VB110

Pneumatic Actuator Torque Data

Valve Size (inches)	DOUBLE ACTING		SPRING RETURN					
	Model	Torque (in-lbs)	Model	Spring Set (standard)	Spring Torque (in-lbs)		Air Torque (in-lbs)	
					Start	End	Start	End
1/2	UT11DA	125	UT11S2	S2	66	44	81	59
3/4	UT11DA	125	UT11S2	S2	66	44	81	59
1	UT11DA	125	UT14S4	S4	150	107	168	125
1-1/4	UT14DA	275	UT14S4	S4	150	107	168	125
1-1/2	UT14DA	275	UT19S5	S5	307	230	270	193
2	UT14DA	275	UT19S5	S5	307	230	270	193
2-1/2	UT19DA	500	UT31S4	S4	502	374	626	498
3	UT19DA	500	UT31S4	S4	502	374	626	498
4	UT26DA	750	UT36S4	S4	824	614	986	776

Pneumatic Actuator Weights and Air Consumption

Valve Size (inches)	DOUBLE ACTING			SPRING RETURN		
	Model	Weight (lbs)	Air Cons. (in3)	Model	Weight (lbs)	Air Cons. (in3)
1/2	UT11DA	1.26	13.5	UT11S2	1.44	8.0
3/4	UT11DA	1.26	13.5	UT11S2	1.44	8.0
1	UT11DA	1.26	13.5	UT14S4	3.06	10.8
1-1/4	UT14DA	2.62	22.0	UT14S4	3.06	10.8
1-1/2	UT14DA	2.62	22.0	UT19S5	5.16	17.5
2	UT14DA	2.62	22.0	UT19S5	5.16	17.5
2-1/2	UT19DA	4.34	40.6	UT31S4	12.3	40.6
3	UT19DA	4.34	40.6	UT31S4	12.3	40.6
4	UT26DA	8.82	68.7	UT36S4	19.9	75.0

VKD SERIES BALL VALVES

Model VB015

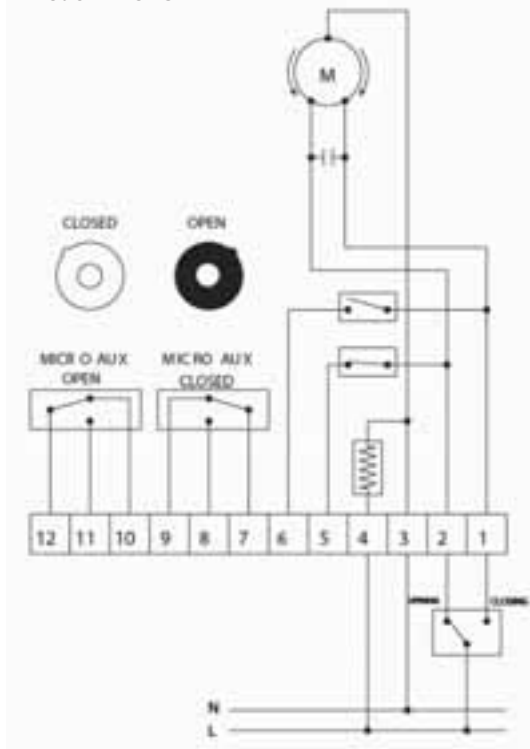

Models VB030, VB060, VB110

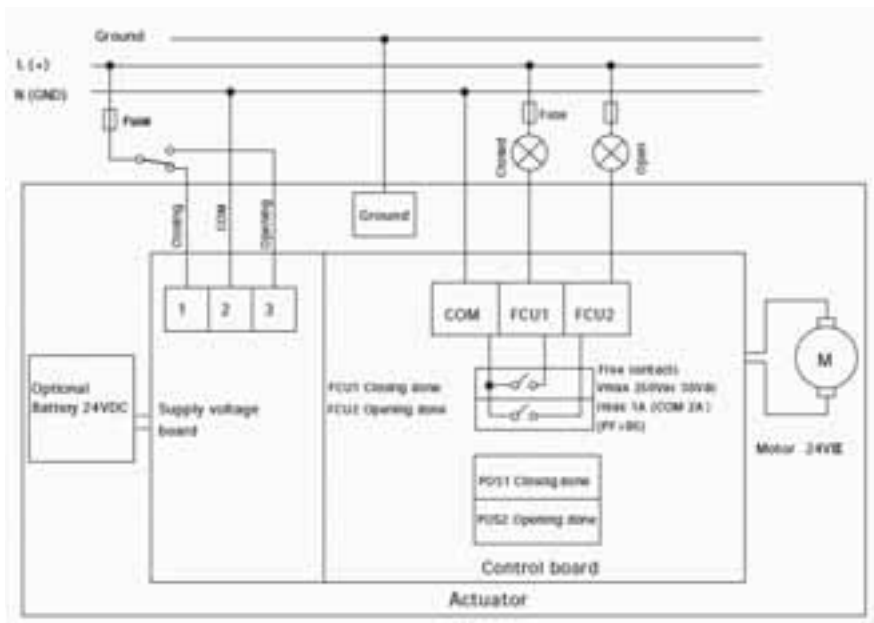

ELECTRICAL ACTUATOR DATA

Model	VB015	VB030	VB060	VB110	
1	Maximum Working Torque (in-lbs)	133	266	530	975
2	Voltage	110 VAC	100 - 240 VAC	100 - 240 VAC	100 - 240 VAC
3	Absorbed Current	50 mA	0.3 - 0.2 A	0.6 - 0.3 A	0.6 - 0.3 A
4	Absorbed Power	6.6 VA	30 - 48 VA	60 - 72 VA	60 - 72 VA
5	Working Time	25 sec	8 sec	9 sec	27 sec
6	Torque Limiter	STD	STD	STD	STD
7	Duty Rating	50%	75%	75%	75%
8	Protection	IP 65-67	IP 65 - 67	IP 65 - 67	IP 65 - 67
9	Rotation	90°	90°	90°	90°
10	Manual Override	STD	STD	STD	STD
11	Position Indicator	STD	STD	STD	STD
12	Working Temperature	-4°F / +131°F	-4°F / +131°F	-4°F / +131°F	-4°F / +131°F
13	Heater	STD	STD	STD	STD
14	Additional Limit Switches	2 STD	2 STD	2 STD	2 STD
15	ISO 5211 Mounting	F03 - F05	F03 - F05	F05 - F07	F07 - F10
16	Square (in)	0.43	0.43	0.55	0.67
17	Electrical Connections	PG11	PG11	PG11	PG11
18	Weight (lbs)	3.09	5.07	7.28	10.80

VKD SERIES BALL VALVES

Components

Sizes 1/2" to 2"

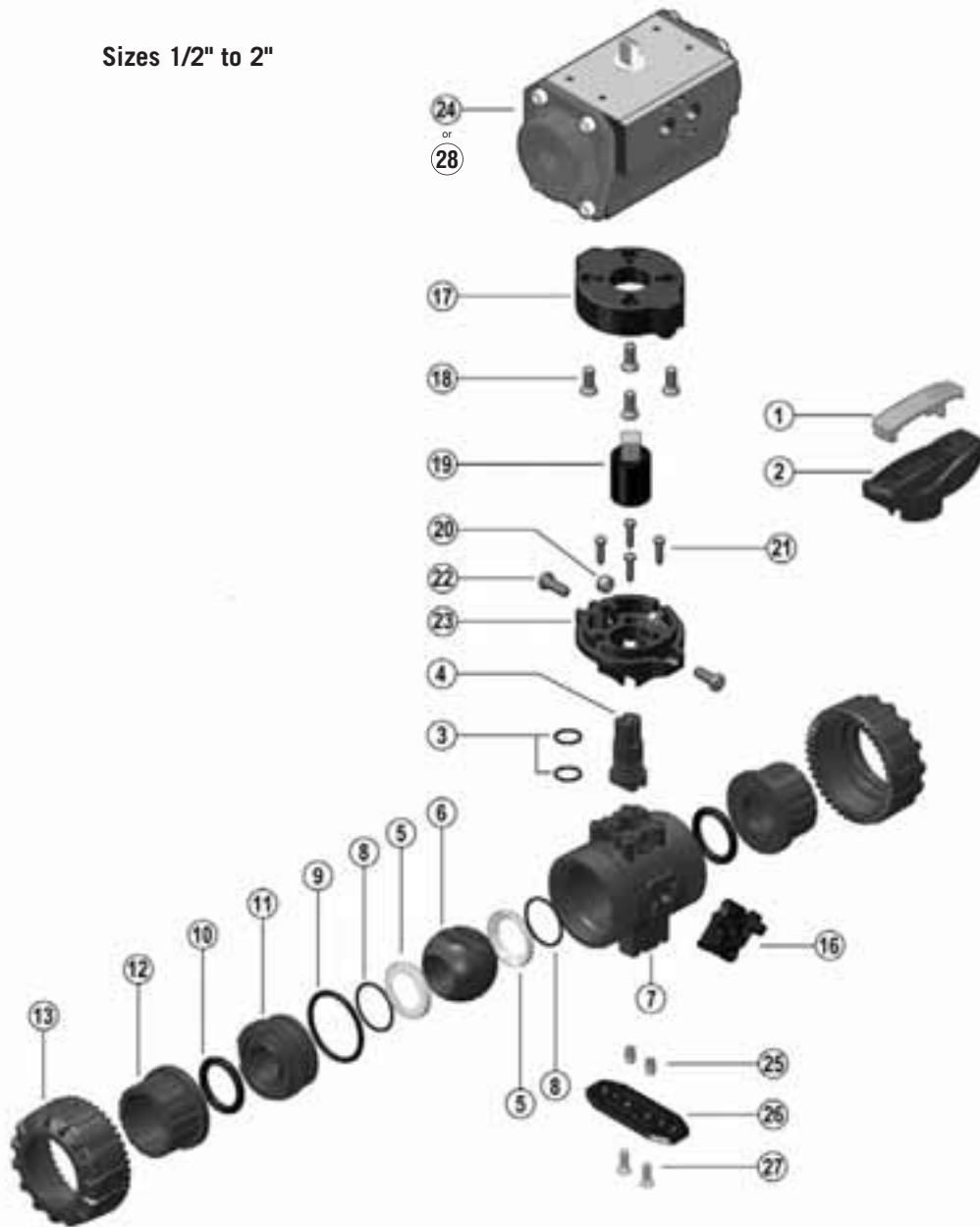

#	Component
1	Insert
2	Handle
3	Stem O-Ring
4	Stem
5	Ball Seat
6	Ball
7	Body
8	Support O-Ring for Ball Seat
9	Radial Seal O-Ring
10	Socket Seal O-Ring
11	Support for Ball Seat
12	End Connector
13	Union Nut

#	Component
16	Dual Block
17	Upper Plate
18	Screw
19	Coupling Spindle
20	Nut
21	Screw
22	Screw
23	Lower Plate
24	Pneumatic Actuator
25	Bracketing Bush
26	Distance Plate
27	Screw
28	Electric Actuator (not shown)

VKD SERIES BALL VALVES

Components

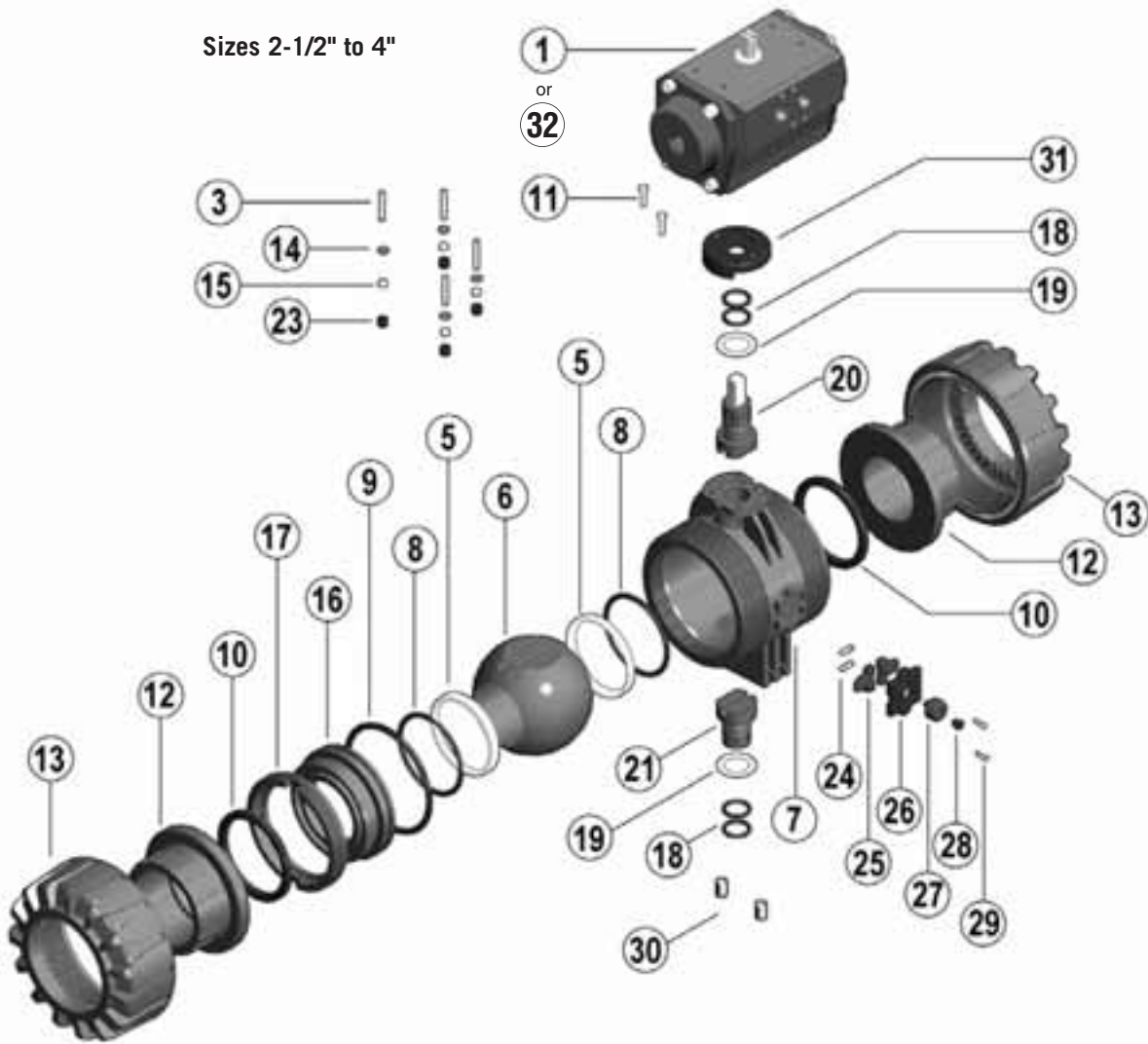

#	Component
1	Pneumatic Actuator
3	Screw
5	Ball Seat
6	Ball
7	Body
8	Support O-ring for Ball Seat
9	Radial Seal O-ring
10	Special Socket Seal
11	Screw
12	End Connector
13	Union Nut
14	Washer
15	Nut
16	Support for Ball Seat
17	Stop Ring

#	Component
18	Stem O-Ring
19	Friction Reducing Bush
20	Upper Stem
21	Lower Stem
22	Pad
23	Protection Cap
24	Spring
25	Nut Block
26	Cover
27	Nut Block Button
28	Protection Cap
29	Screw
30	Bracketing Bush
31	Actuation Adapter
32	Electric Actuator (not shown)

VKD SERIES BALL VALVES

Installation Procedures

1. Remove the union nuts (part #13 on previous page) and slide them onto the pipe.
2. Please refer to the appropriate connection style sub-section:
 - a. For socket style, solvent cement or fuse the end connectors (12) onto the pipe ends. For correct solvent cementing procedure, please refer to the section entitled, "Joining Methods – Solvent Cementing" in the IPEX Industrial Technical Manual Series, "Volume I: Vinyl Process Piping Systems". Be sure to allow sufficient cure time before continuing with the valve installation.
 - b. For threaded style, thread the end connectors (12) onto the pipe ends. For correct joining procedure, please refer to the section entitled, "Joining Methods – Threading" in the IPEX Industrial Technical Manual Series, "Volume I: Vinyl Process Piping Systems".
3. All quarter turn automated valves are tested for proper operation before leaving the factory. Adjustment of the seat stop carrier should not be necessary. However, if adjustment is required, ensure that the valve is in the closed position then remove the insert tool (1) from the handle (2), supplied loose. For sizes 2-1/2" to 4", use the tool that accompanies the valve. Line up the moldings on the tool with the slots in the carrier. Tighten or loosen to the desired position then replace the tool on the handle.
4. Ensure that the valve is in the closed position, and that the socket o-rings (10) are properly fitted in their grooves. If anchoring is required, insert the bracket bushings (25) into the bottom of the valve (sizes 1/2" to 2" only). Carefully place the valve in the system between the two end connections and fix if necessary.
5. Tighten the union nut on the side opposite to that which is marked "ADJUST". Hand tightening is typically sufficient to maintain a seal for the maximum working pressure. Over-tightening may damage the threads on the valve body and/or the union nut, and may even cause the union nut to crack.
6. Tighten the union nut on the side marked "ADJUST". Tightening the union nuts in this order results in the best possible valve performance due to optimum positioning and sealing of the ball and seat support system.
7. Connect pneumatic or electric connections according to provided diagrams.
8. Cycle the valve open and close to ensure that the cycling performance is adequate. If adjustment is required, place the valve in the closed position, loosen the union nuts, remove the valve from the system, and then continue from Step 3.
9. Engage the Dual Block® system by affixing the molded piece (16, sizes 1/2" to 2") to the side of the valve body or by turning the red knob (27, sizes 2-1/2" to 4") to the locked position. This feature will prevent back-off of the union nuts during operation.



2-1/2" - 4" Dual Block® Mechanism



1/2" - 2" Dual Block® Mechanism

VKD SERIES BALL VALVES

Valves Maintenance

Disassembly

1. If removing the valve from an operating system, isolate the valve from the rest of the line. Be sure to depressurize and drain the valve and isolated branch. It is recommended that all actuators be de-activated before servicing the valve to avoid injury.
2. If necessary, remove actuator connections and detach the valve from the support structure by disassembling the connections to the bracket on the optional bottom of the valve body (7).
3. Unlock the Dual Block® system by compressing the two ends of the molded piece (16, sizes 1/2" to 2") or by turning the red knob (27, sizes 2-1/2" to 4") to the unlocked position. Loosen both union nuts (13) and drop the valve out of the line. If retaining the socket o-rings (10), take care that they are not lost when removing the valve from the line.
4. Remove the actuator, if necessary, from the valve by removing the screws (22) located horizontally across from each other (sizes 1/2" to 2"). On sizes 2-1/2" to 4", remove the actuator by loosening and removing the bolts (3), washers (14), nuts (15), and caps (23).
5. Ensure the valve is in the closed position. If it is not, rotate the ball using the exposed stem or stem extension, making sure not to damage. Line up the moldings on the wrench tool (1, sizes 1/2" to 2") with the slots in the carrier (found on the side marked "ADJUST"). Loosen and remove the carrier (11 or 16).
6. Carefully press the ball (6) out of the valve body, taking care not to score or damage the outer surface.
7. Press the stem (4 or 20) into the valve body from above. On sizes 2-1/2" to 4", remove the lower stem (21) by pushing it into the valve body from below.
8. The stem o-rings (3 or 18), body o-ring (9), ball seats (5), ball seat o-rings (8), and bushings (19, sizes 2-1/2" to 4") can now be removed and/or replaced.

Note: It is not typically necessary to disassemble the Dual Block® components (sizes 2-1/2" to 4"). It is not necessary to remove the actuator from the valve unless the stem requires servicing or replacement. If possible, leave actuator attached to valve during servicing.



Assembly

Note: Before assembling the valve components, it is advisable to lubricate the o-rings with a water soluble lubricant. Be sure to consult the "IPEX Chemical Resistance Guide" and/or other trusted resources to determine specific lubricant-rubber compatibilities.

1. Replace the stem o-rings (3 or 18), body o-ring (9), ball seat o-rings (8), ball seats (5), and bushings (19, sizes 2-1/2" to 4") in their proper positions.
2. Insert the stem (4 or 20) into position from inside the valve body (7). On sizes 2-1/2" to 4", insert the lower stem (21) as well.
3. On sizes 2-1/2" to 4", replace the actuation adapter plate and affix in position using the bolts (11), washers (14), and nuts (15). Replace the caps (23) over the nuts.
4. Replace the stem extension, if applicable.
5. Carefully insert the ball (6) into the valve body, taking care not to score or damage the outer surface. Ensure that the actuator and ball position correspond to the same operating position.
6. Insert the threaded carrier (11 or 16) and tighten into the valve body. Use the wrench tool to sufficiently tighten.
7. Replace the actuator, if removed, and affix in position using screws (22) installed horizontally (1/2" to 2") or bolts (3), washers (14), nuts (15), and caps (23) (2-1/2" to 4").
7. Place the end connectors (12) into the union nuts (13), then thread onto the valve body taking care that the socket o-rings remain properly fitted in their grooves.
8. Engage the Dual Block® system by affixing the molded piece (16, sizes 1/2" to 2") to the side of the valve body or by turning the red knob (27, sizes 2-1/2" to 4") to the locked position.



VX SERIES BALL VALVES

IPEX VX Series Automated Ball Valves are ideal for general purpose and O.E.M. applications. These valves feature an ultra-compact double block design, and full port bi-directional operation. The true union design allows the valve to be easily removed from the piping system and fully serviced. A threaded seat stop carrier provides improved seal integrity under tough service conditions. VX Series Automated Ball Valves are part of our complete systems of pipe, valves, and fittings, engineered and manufactured to our strict quality, performance, and dimensional standards.

Valve Availability

Body Material:	PVC, CPVC
Size Range:	1/2" through 2"
Pressure:	232psi
Seats:	Teflon® (PTFE)
Seals:	EPDM or Viton® (FKM)
End Connections:	Socket (IPS), Threaded (FNPT)
Actuator Control:	Double Acting Pneumatic, Spring Return Pneumatic, Electric

Standards



ASTM D1784
 ASTM D2464
 ASTM D2466
 ASTM D2467
 ASTM F437
 ASTM F439
 ASTM F1498

ANSI B1.20.1



VX SERIES BALL VALVES

Samples Specificaiton

1.0 Ball Valves - VX

1.1 Material

- The valve body, stem, ball and unions shall be made of PVC compound which shall meet or exceed the requirements of cell classification 12454 according to ASTM D1784.
- or The valve body, stem, ball and unions shall be made of Corzan® CPVC compound which shall meet or exceed the requirements of cell classification 23447 according to ASTM D1784.

1.2 Seats

- The ball seats shall be made of Teflon® (PTFE).

1.3 Seals

- The o-ring seals shall be made of EPDM.
- or The o-ring seals shall be made of Viton® (FKM).

1.4 All wetted parts of the valves shall comply with standards that are equivalent to NSF Standard 61 for potable water.

2.0 Connections

2.1 Socket Style

- The IPS socket PVC end connectors shall conform to the dimensional standards ASTM D2466 and ASTM D2467.
- or The IPS socket CPVC end connectors shall conform to the dimensional standard ASTM F439.

2.2 Threaded Style

- The female NPT threaded PVC end connectors shall conform to the dimensional standards ASTM D2464, ASTM F1498 and ANSI B1.20.1.
- or The female NPT threaded CPVC end connectors shall conform to the dimensional standards ASTM F437, ASTM F1498 and ANSI B1.20.1.

3.0 Design Features

- The valve shall be double blocking with union ends.
- All valves shall be full port.
- All valves shall allow for bi-directional flow.
- The valve body shall be single end entry with a threaded carrier (ball seat support).
- The threaded carrier shall be adjustable with the valve installed.
- The valve body shall have an expansion and contraction compensating groove on the molded end.
- The valve body, union nuts, and carrier shall have deep square style threads for increased strength.
- The ball and stem shall be machined smooth to minimize wear on valve seats and seals.
- The stem design shall feature a shear point above the o-ring to maintain system integrity in the unlikely event of a stem breakage.

3.1 Pressure Tested

- All valves shall have been pressure tested in both the open and closed positions by the manufacturer.

3.2 Pressure Rating

- All valves shall be rated at 232psi at 73°F.

3.3 Markings

- All valves shall be marked to indicate size, material designation, and manufacturer's name or trade mark.

3.4 Color Coding

- All PVC valves shall be color-coded dark gray.
- or All CPVC valves shall be color-coded light gray.

4.0 All valves shall be Xirtec®140 or Corzan® by IPEX or approved equal.

5.0 Actuators

- All actuators shall be factory installed by IPEX.
- Pneumatic actuators shall be dual piston rack and pinion design, sized for 80psi control air pressure.
- Electric actuators shall have 110 VAC reversing motors, torque limiters, thermal protection, and NEMA 4 or equivalent housings.

VX SERIES BALL VALVES

Dimensions

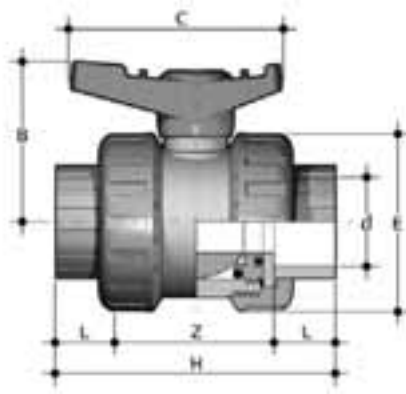

DIMENSIONS (inches)

Size	d	L	Z	H	E	B	C
1/2	0.84	0.89	2.01	3.78	2.09	1.97	2.56
3/4	1.05	1.00	2.13	4.13	2.44	2.28	2.99
1	1.32	1.13	2.34	4.61	2.80	2.56	3.35
1-1/4	1.66	1.26	2.83	5.35	3.31	2.99	3.94
1-1/2	1.90	1.38	3.03	5.79	3.86	3.35	4.41
2	2.38	1.50	3.84	6.85	4.61	4.06	5.39

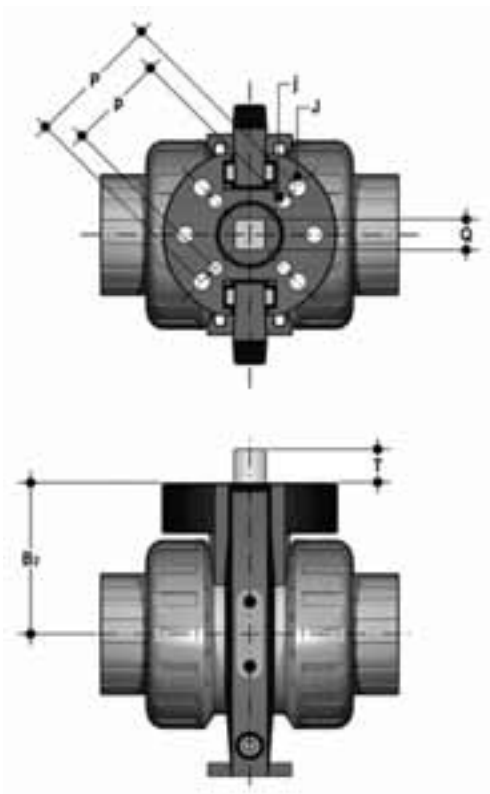

DIMENSIONS (inches)

Size	B2	T	Q	p / P	j / J
1/2	1.86	0.43	0.43	F04/F05	0.22 / 0.26
3/4	2.12	0.43	0.43	F04/F05	0.22 / 0.26
1	2.29	0.43	0.43	F04/F05	0.22 / 0.26
1-1/4	2.69	0.43	0.43	F04/F05	0.22 / 0.26
1-1/2	3.13	0.47 / 0.58	0.43 / 0.55	F05/F07	0.26 / 0.33
2	3.60	0.47 / 0.58	0.43 / 0.55	F05/F07	0.26 / 0.33

VX SERIES BALL VALVES

Models UT11, UT14, UT19

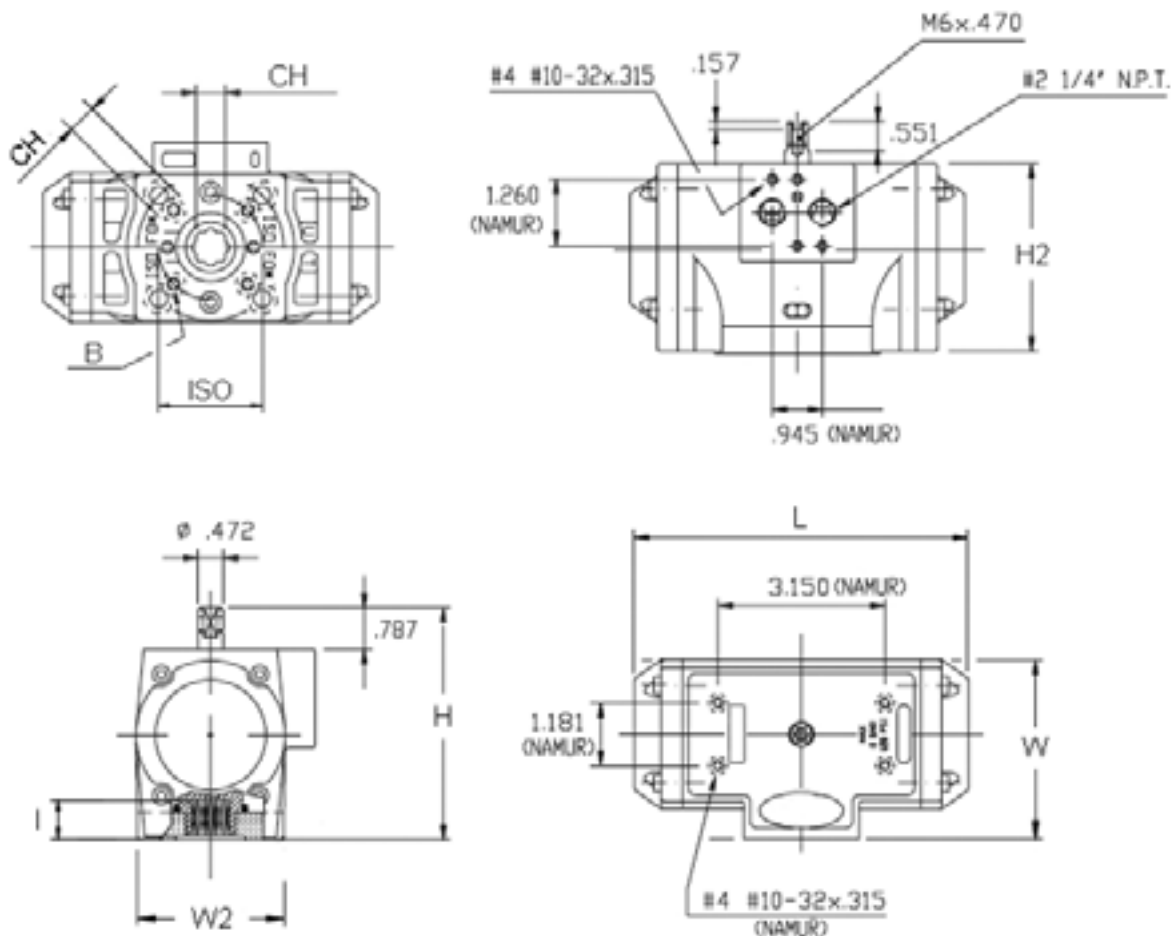

DIMENSIONS (inches)

Valve Size	Double Acting Model	ISO	CH	L	W	W2	H	H2	I	B
1/2	UT11DA	F04	0.43	4.69	2.64	2.09	3.58	2.76	0.49	10-32 UNF x 0.40
3/4	UT11DA	F04	0.43	4.69	2.64	2.09	3.58	2.76	0.49	10-32 UNF x 0.40
1	UT11DA	F04	0.43	4.69	2.64	2.09	3.58	2.76	0.49	10-32 UNF x 0.40
1-1/4	UT11DA	F04	0.43	4.69	2.64	2.09	3.58	2.76	0.49	10-32 UNF x 0.40
1-1/2	UT14DA	F05 / F07	0.55	6.30	3.39	2.76	4.37	3.54	0.75	1/4-20 UNC x 0.51
2	UT14DA	F05 / F07	0.55	6.30	3.39	2.76	4.37	3.54	0.75	1/4-20 UNC x 0.51

DIMENSION (inches)

Valve Size	Spring Return Model	ISO	CH	L	W	W2	H	H2	I	B
1/2	UT11S2	F04	0.43	4.69	2.64	2.09	3.58	2.76	0.49	10-32 UNF x 0.40
3/4	UT11S2	F04	0.43	4.69	2.64	2.09	3.58	2.76	0.49	10-32 UNF x 0.40
1	UT14S4	F05 / F07	0.55	6.30	3.39	2.76	4.37	3.54	0.75	1/4-20 UNC x 0.51
1-1/4	UT14S4	F05 / F07	0.55	6.30	3.39	2.76	4.37	3.54	0.75	1/4-20 UNC x 0.51
1-1/2	UT19S5	F05 / F07	0.67	6.89	3.98	2.76	5.22	4.39	0.91	5/16-18 UNC x 0.51
2	UT19S5	F05 / F07	0.67	6.89	3.98	2.76	5.22	4.39	0.91	5/16-18 UNC x 0.51

VX SERIES BALL VALVES

Electric Actuator Dimensions

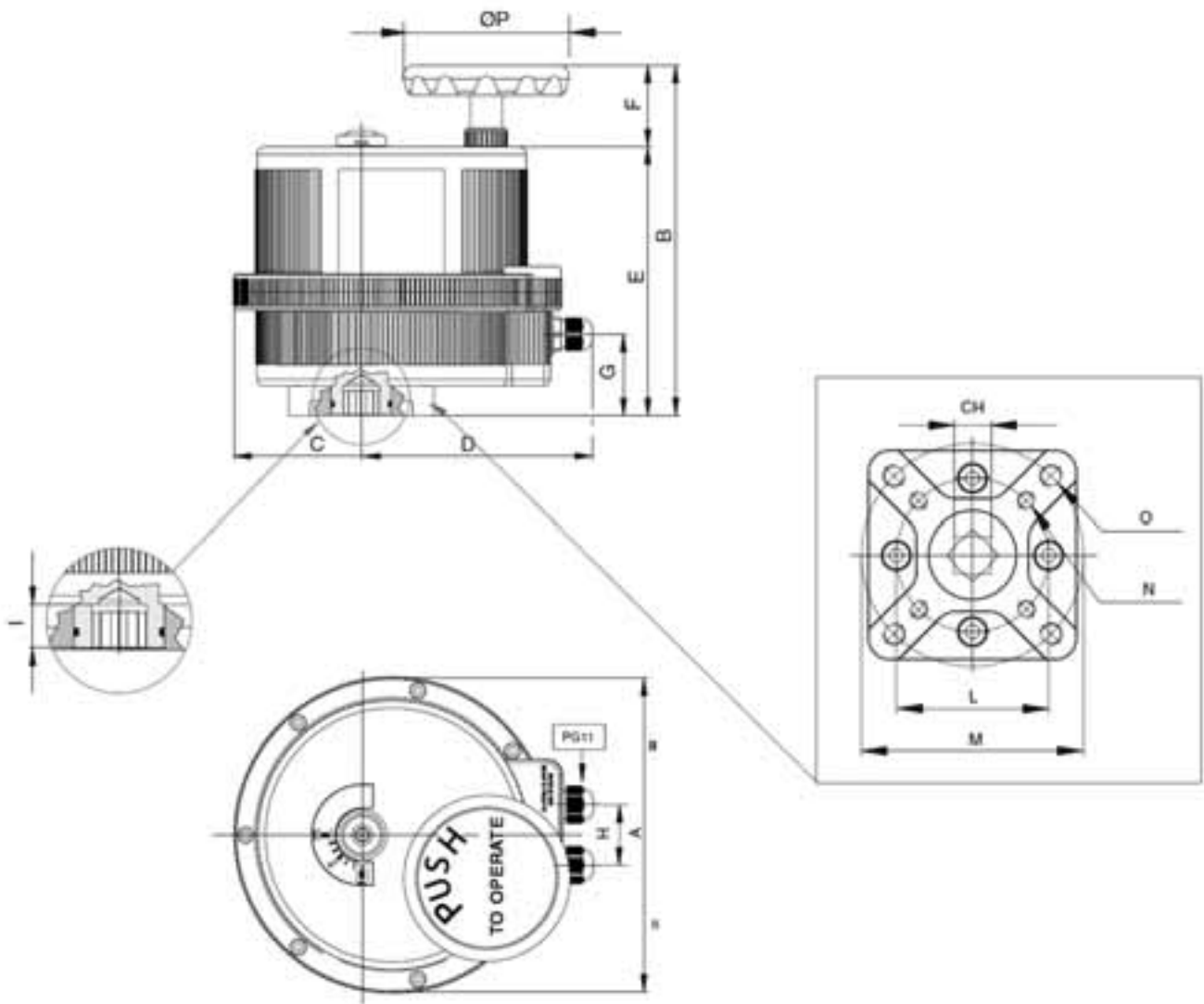

DIMENSIONS (inches)

Valve Size	Actuator Model	ISO	CH	A	B	C	D	E	F	G	H	I	L	M	N	O
1/2	VB015	F03 / F05	0.43	4.84	6.28	1.67	4.78	5.67	0.61	4.35	1.26	0.47	1.42	1.97	10-24 UNC x 0.55	1/4-20 UNC x 0.55
3/4	VB015	F03 / F05	0.43	4.84	6.28	1.67	4.78	5.67	0.61	4.35	1.26	0.47	1.42	1.97	10-24 UNC x 0.55	1/4-20 UNC x 0.55
1	VB015	F03 / F05	0.43	4.84	6.28	1.67	4.78	5.67	0.61	4.35	1.26	0.47	1.42	1.97	10-24 UNC x 0.55	1/4-20 UNC x 0.55
1-1/4	VB015	F03 / F05	0.43	4.84	6.28	1.67	4.78	5.67	0.61	4.35	1.26	0.47	1.42	1.97	10-24 UNC x 0.55	1/4-20 UNC x 0.55
1-1/2	VB015	F03 / F05	0.43	4.84	6.28	1.67	4.78	5.67	0.61	4.35	1.26	0.47	1.42	1.97	10-24 UNC x 0.55	1/4-20 UNC x 0.55
2	VB030	F03 / F05	0.43	6.18	7.39	2.38	5.01	5.75	1.64	1.30	1.42	0.47	1.42	1.97	10-24 UNC x 0.55	1/4-20 UNC x 0.55

VX SERIES BALL VALVES



Note:

Pneumatic actuator performance is based on 80psi available control air pressure

Actuator Technical Data

Valve Size (inches)	Double Acting Pneumatic	Spring Return Pneumatic	Electric
1/2	UT11DA	UT11S2	VB015
3/4	UT11DA	UT11S2	VB015
1	UT11DA	UT14S4	VB015
1-1/4	UT11DA	UT14S4	VB015
1-1/2	UT14DA	UT19S5	VB015
2	UT14DA	UT19S5	VB030

Pneumatic Actuator Torque Data

Valve Size (inches)	DOUBLE ACTING		SPRING RETURN					
	Model	Torque (in-lbs)	Model	Spring Set (standard)	Spring Torque (in-lbs)		Air Torque (in-lbs)	
					Start	End	Start	End
1/2	UT11DA	125	UT11S2	S2	66	44	81	59
3/4	UT11DA	125	UT11S2	S2	66	44	81	59
1	UT11DA	125	UT14S4	S4	150	107	168	125
1-1/4	UT11DA	125	UT14S4	S4	150	107	168	125
1-1/2	UT14DA	275	UT19S5	S5	307	230	270	193
2	UT14DA	275	UT19S5	S5	307	230	270	193

Pneumatic Actuator Weights and Air Consumption

Valve Size (inches)	DOUBLE ACTING			SPRING RETURN		
	Model	Weight (lbs)	Air Cons. (in ³)	Model	Weight (lbs)	Air Cons. (in ³)
1/2	UT11DA	1.26	13.5	UT11S2	1.44	8.0
3/4	UT11DA	1.26	13.5	UT11S2	1.44	8.0
1	UT11DA	1.26	13.5	UT14S4	3.06	10.8
1-1/4	UT11DA	1.26	13.5	UT14S4	3.06	10.8
1-1/2	UT14DA	2.62	22.0	UT19S5	5.16	17.5
2	UT14DA	2.62	22.0	UT19S5	5.16	17.5

VX SERIES BALL VALVES

Model VB015

Models VB030

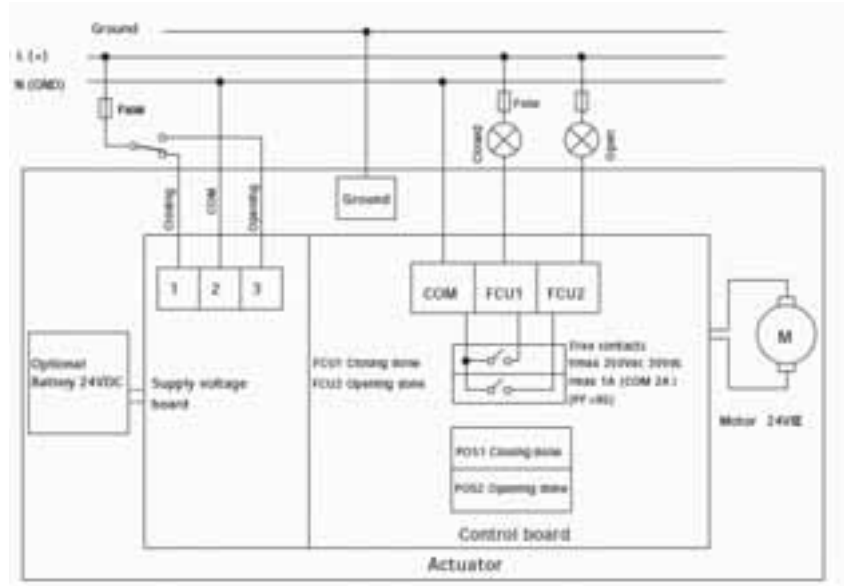
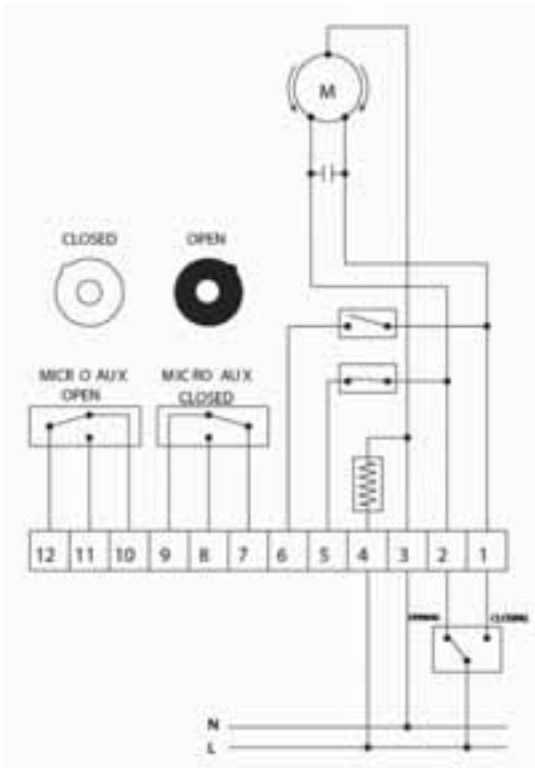

ELECTRICAL ACTUATOR DATA

Model	VB015	VB030	
1	Maximum Working Torque (in-lbs)	133	266
2	Voltage	110 VAC	100-240 VAC
3	Absorbed Current	50 mA	0.3-0.2 A
4	Absorbed Power	6.6 VA	30-48 VA
5	Working Time	25 sec	8 sec
6	Torque Limiter	STD	STD
7	Duty Rating	50%	75%
8	Protection	IP 65-67	IP 65-67
9	Rotation	90°	90°
10	Manual Override	STD	STD
11	Position Indicator	STD	STD
12	Working Temperature	-4°F / +131°F	-4°F / +131°F
13	Heater	STD	STD
14	Additional Limit Switches	2 STD	2 STD
15	ISO 5211 Mounting	F03 F05	F03 F05
16	Square (in)	0.43	0.43
17	Electrical Connections	PG11	PG11
18	Weight (lbs)	3.09	5.07

VX SERIES BALL VALVES

Components

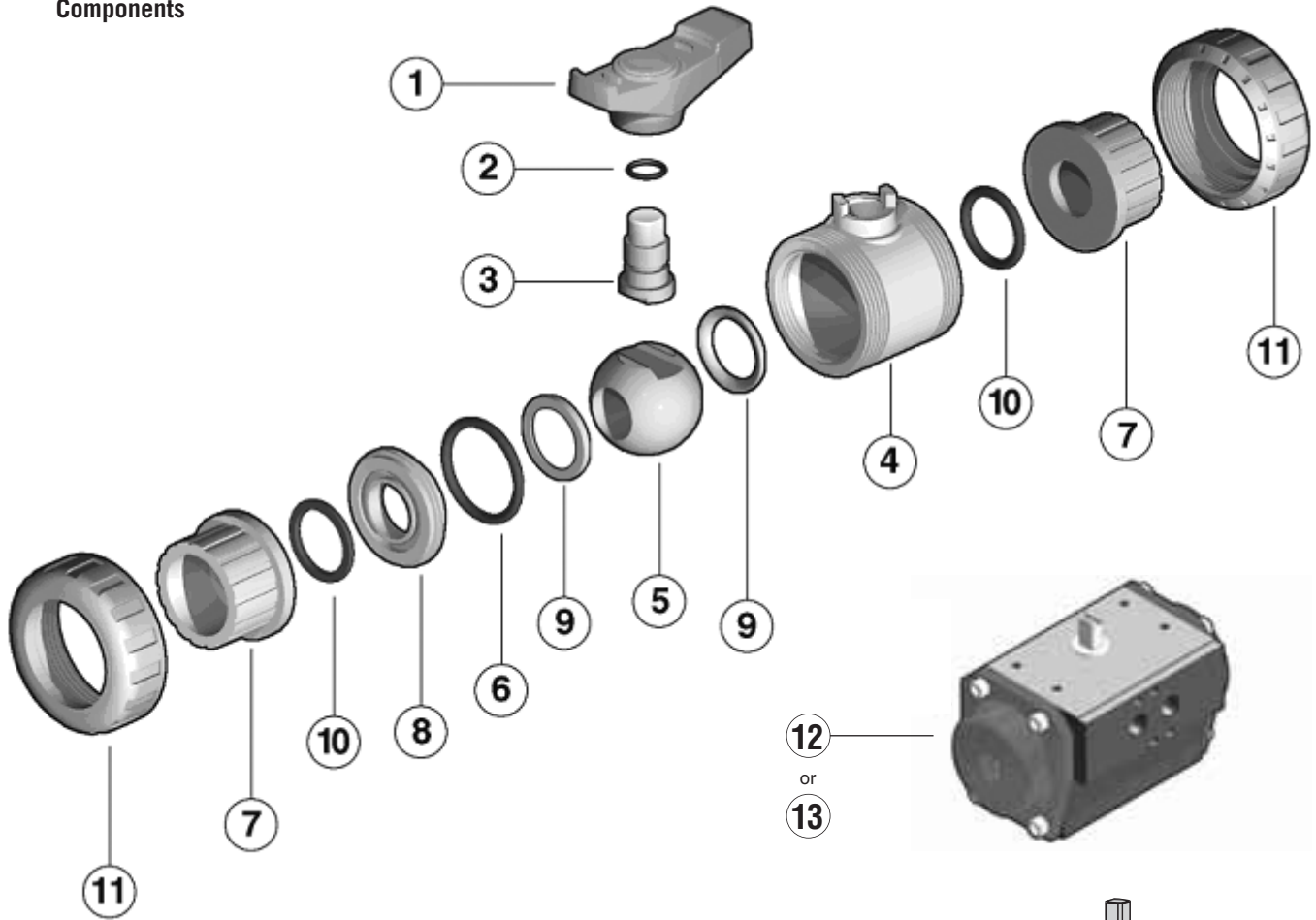

BALL VALVES

#	Component
1	Handle
2	Stem O-Ring
3	Stem
4	Body
5	Ball
6	Body O-Ring
7	End Connector
8	Support for Ball Seat
9	Ball Seat
10	Socket O-Ring
11	Union Nut
12	Pneumatic Actuator
13	Electric Actuator (not shown)
14	Stem Extension
15	Hex Bolt
16	Nut
17	Mounting Saddle

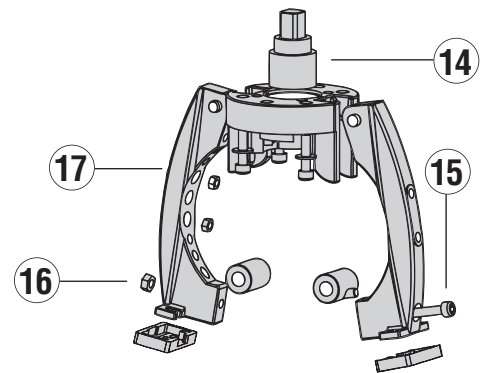

VX SERIES BALL VALVES

Installation Procedures

1. For socket and threaded style connections, remove the union nuts (part #11 on previous page) and slide them onto the pipe. For flanged connections, remove the union nut / flange assemblies from the valve.
2. Please refer to the appropriate connection style subsection:
 - a. For socket style, solvent cement the end connectors (7) onto the pipe ends. For correct joining procedure, please refer to the section entitled, "Joining Methods – Solvent Cementing" in the IPEX Industrial Technical Manual Series, "Volume I: Vinyl Process Piping Systems". Be sure to allow sufficient cure time before continuing with the valve installation.
 - b. For threaded style, thread the end connectors (7) onto the pipe ends. For correct joining procedure, please refer to the section entitled, "Joining Methods – Threading" in the IPEX Industrial Technical Manual Series, "Volume I: Vinyl Process Piping Systems".
 - c. For flanged style, join the union nut / flange assemblies to the pipe flanges. For correct joining procedure, please refer to the section entitled, "Joining Methods – Flanging" in the IPEX Industrial Technical Manual Series, "Volume I: Vinyl Process Piping Systems".
3. All quarter turn automated valves are tested for proper operation before leaving the factory. Adjustment should not be necessary. However, if ball seat adjustment is required, ensure that the valve is in the closed position then use the provided handle (1) to adjust. Line up the moldings on the handle with the slots in the ball seat support. Tighten or loosen to the desired position then replace the handle on the valve stem.



4. Ensure that the valve is in the closed position, and that the socket o-rings (10) are properly fitted in their grooves. Carefully place the valve in the system between the two end connections.
5. Tighten the union nut on the side opposite to that which is marked "ADJUST". Hand tightening is typically sufficient to maintain a seal for the maximum working pressure. Over-tightening may damage the threads on the valve body and/or the union nut and may even cause the union nut to crack.



6. Tighten the union nut on the side marked "ADJUST". Tightening the union nuts in this order results in the best possible valve performance due to optimum positioning and sealing of the ball and seat support system.
7. Connect pneumatic or electric connections according to provided diagrams.
8. Cycle the valve open and close to ensure that the cycling performance is adequate. If adjustment is required, place the valve in the closed position, loosen the union nuts, remove the valve from system and then continue from Step 3.

VX SERIES BALL VALVES

Valve Maintenance

Disassembly

1. If removing the valve from an operating system, isolate the valve from the rest of the system. Be sure to depressurize and drain the isolated branch and valve before continuing. It is recommended that all actuators be de-activated before servicing the valve to avoid injury.
2. If necessary, remove actuator connections.
3. Loosen both union nuts (11) and drop the valve out of the line. If retaining the socket o-rings (10), take care that they are not lost when removing the valve from the line.
4. Remove the actuator assembly if necessary, including the saddle and stem extension, from the valve by removing the bottom bolt (15).
3. To disassemble, place the valve in the closed position using the provided handle.

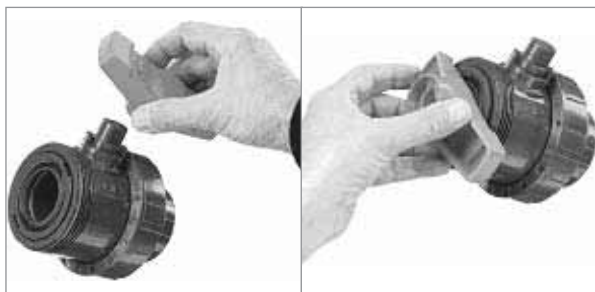

4. Line up the moldings on the handle with the slots in the ball seat support (found on the side marked "ADJUST"). Loosen and remove the ball seat support (8) by turning in a counterclockwise direction.
5. Carefully press the ball (5) out of the valve body, taking care not to score or damage the outer surface.
6. To remove the stem (3), press it into the valve body (4) from above.
7. The stem o-ring (2), body o-ring (6), and ball seats (9) can now be removed and/or replaced

Assembly

Note: Before assembling the valve components, it is advisable to lubricate the o-rings with a water soluble lubricant. Be sure to consult the "IPEX Chemical Resistance Guide" and/or other trusted resources to determine specific lubricant-rubber compatibilities.

1. Firmly place the ball seat (9) in the groove on the opposite end inside the valve body (4).
2. Properly fit the stem o-ring (2) in the groove on the stem (3) then insert the stem from the inside of the valve body.
3. Ensure that the valve stem is in the closed position then insert the ball (5) into the valve body taking care not to score or damage the outer surface.
3. Ensure that the actuator and ball position correspond to the same operating position.
4. Check that the ball seat (9) and body o-ring (6) are properly fitted on the ball seat support (8), then slightly hand tighten into the valve body. Line up the moldings on the provided handle (1) with the slots in the ball seat support then tighten by turning in a clockwise direction.
5. Replace the actuator and affix in position using bolt on bottom of saddle (15).
6. Properly fit the socket o-rings (10) in their respective grooves.
7. Place the end connectors (7) into the union nuts (11), then thread onto the valve body taking care that the socket o-rings remain properly fitted in their grooves.
8. Cycle the valve open and closed to determine whether or not the performance is adequate. If so desired, remove valve from line and use provided handle to make further adjustments.

TKD SERIES 3-WAY BALL VALVES

IPEX TKD Series 3-Way Automated Ball Valves can be used for flow diverting, mixing, or on/off isolation. They offer a variety of advanced features such as the patented seat stop carrier, a high quality stem and ball support system, and the new DUAL BLOCK® system which locks the union nuts preventing back-off due to vibration or thermal cycling. Deep grooves, thick o-rings, and cushioned Teflon® seats contribute to strong seals at pressures up to 232psi while an integral mounting flange and support bracketing combine for simple adaptation for actuation and anchoring. Actuators can be configured for 90° or 180° operation. TKD Series 3-Way Automated Ball Valves are part of our complete systems of pipe, valves, and fittings, engineered and manufactured to our strict quality, performance, and dimensional standards.

Valve Availability

Body Material:	PVC
Size Range:	1/2" through 2"
Pressure:	232psi
Seats:	Teflon® (PTFE)
Seals:	EPDM or Viton® (FKM)
End Connections:	Socket (IPS), Threaded (FNPT)
Actuator Control:	Double Acting Pneumatic, Spring Return Pneumatic, Electric

Standards



ASTM D1784
ASTM D2464
ASTM D2466
ASTM D2467
ASTM F1498



ANSI B1.20.1



TKD SERIES 3-WAY BALL VALVES

Samples Specifications

1.0 Ball Valves - TKD

1.1 Material

- The valve body, stem, ball, end connectors and unions shall be made of PVC compound which shall meet or exceed the requirements of cell classification 12454 according to ASTM D1784.

1.2 Seats

- The ball seats shall be made of Teflon® (PTFE).

1.3 Seals

- The o-ring seals shall be made of EPDM.
- or The o-ring seals shall be made of Viton® (FKM).

- 1.4 All other wetted parts of the valves shall comply with standards that are equivalent to NSF Standard 61 for potable water.

2.0 Connections

2.1 Socket style

- The IPS socket PVC end connectors shall conform to the dimensional standards ASTM D2466 and ASTM D2467.

2.2 Threaded style

- The female NPT threaded PVC end connectors shall conform to the dimensional standards ASTM D2464, ASTM F1498 and ANSI B1.20.1.

3.0 Design Features

- All valves shall be true union at all three ports.
- All valves shall be full port.
- Valve design shall permit positive shutoff of any of the three ports.
- Balls shall be of T-port or L-port design (specifier must select one).
- The valve shall have blocking seat supports at all three ports.
- The threaded carrier (ball seat support) shall be adjustable with the valve installed.
- The valve body, union nuts and carrier shall have deep square style threads for increased strength.
- The ball shall be machined smooth to minimize wear on valve seats.
- All valve seats shall have o-ring backing cushions to compensate for wear and prevent seizure of the ball.
- The thickness of the valve body shall be the same at all three ports.
- The valve shall include the Dual Block® union nut locking mechanism.
- The stem design shall feature a shear point above the o-ring to maintain system integrity in the unlikely event of a stem breakage.
- All valves shall have integrally molded mounting flanges for support and actuation.

3.1 Pressure Rating

- All valves shall be rated at 232psi at 73°F (23°C).

3.2 Markings

- All valves shall be marked to indicate size, material designation, and manufacturer's name or trade mark.

3.3 Color Coding

- All PVC valves shall be color-coded dark gray.

- 4.0 All valves shall be Xirtec®140 by IPEX or approved equal.

5.0 Actuators

- All actuators shall be factory installed by IPEX.
- Pneumatic actuators shall be dual piston rack and pinion design, sized for 80psi control air pressure.
- Electric actuators shall have 110 VAC reversing motors, torque limiters, thermal protection and NEMA 4 or equivalent housings.

TKD SERIES 3-WAY BALL VALVES

Dimensions

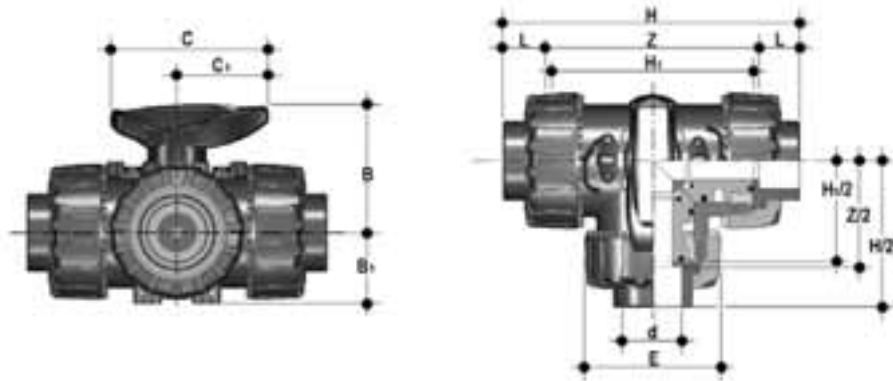

DIMENSIONS (inches)

Size	d	C	C1	B	B1	L	Z	H	H1	E
1/2	0.84	2.64	1.57	2.13	1.14	0.91	3.43	5.20	3.15	2.13
3/4	1.05	3.35	1.93	2.56	1.36	1.00	4.26	6.27	3.94	2.56
1	1.32	3.35	1.93	2.74	1.54	1.13	4.59	6.85	4.33	2.87
1-1/4	1.66	4.25	2.52	3.25	1.81	1.26	5.55	8.07	5.16	3.39
1-1/2	1.90	4.25	2.52	3.50	2.05	1.38	6.20	8.96	5.83	3.86
2	2.38	5.28	2.99	4.25	2.44	1.50	7.50	10.51	7.05	4.80

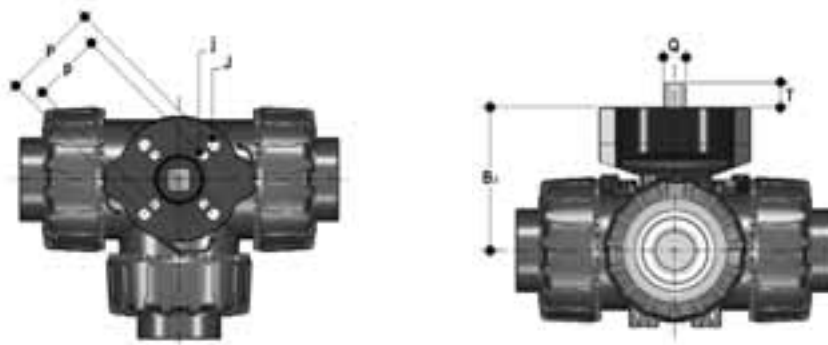

DIMENSIONS (INCHES)

Size	a	T	Q	p / P	j / J
1/2	2.28	0.47	0.43	F03 / F04	0.22
3/4	2.89	0.47	0.43	F03 / F05 or F04	0.22 / 0.26 or 0.22
1	2.91	0.47	0.43	F03 / F05 or F04	0.22 / 0.26 or 0.22
1-1/4	3.82	0.63	0.43 or 0.55	F05	0.26
1-1/2	4.09	0.63	0.43 or 0.55	F05	0.26
2	4.49	0.63	0.43 or 0.55	F05 / F07	0.26 / 0.33

TKD SERIES 3-WAY BALL VALVES

Models UT11, UT14, UT19

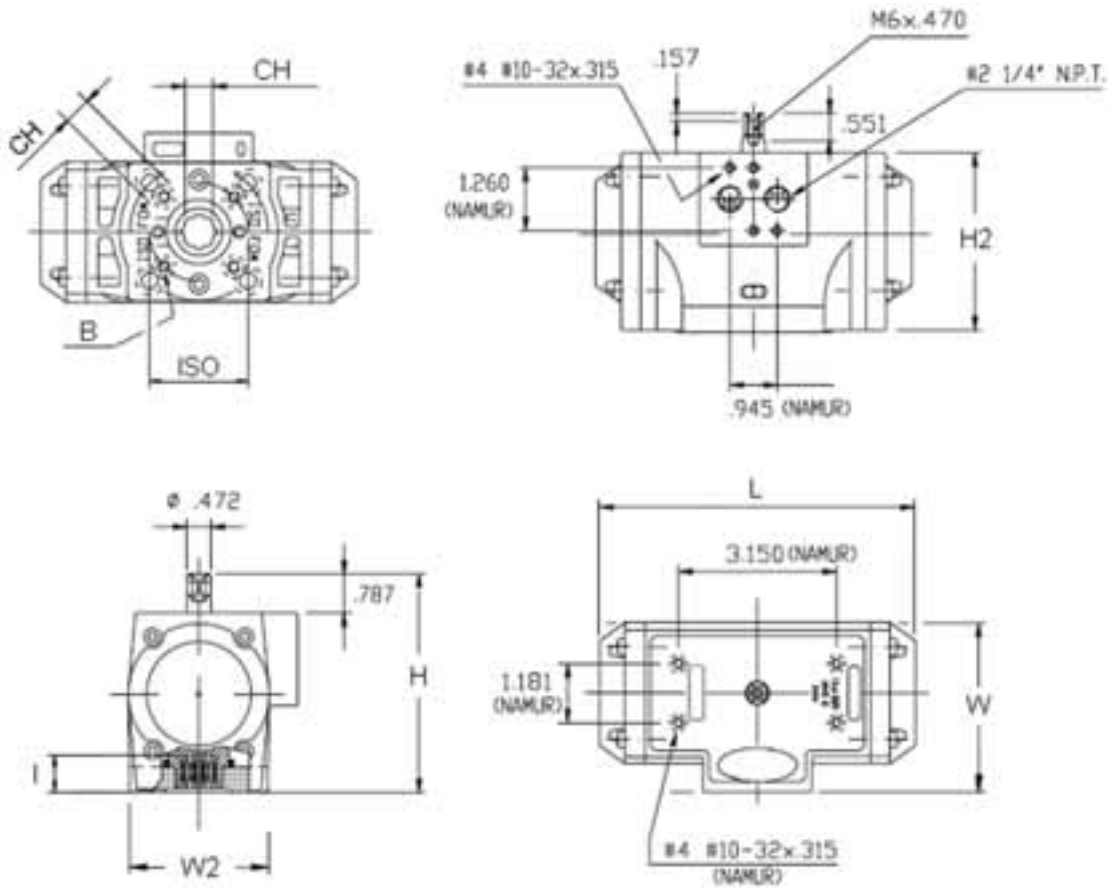

DIMENSIONS (inches)

Valve Size	Double Acting Model	ISO	CH	L	W	W2	H	H2	I	B
1/2	UT11DA	F04	0.43	4.69	2.64	2.09	3.58	2.76	0.49	10-32 UNF x 0.40
3/4	UT14DA	F05 / F07	0.55	6.30	3.39	2.76	4.37	3.54	0.75	1/4-20 UNC x 0.51
1	UT14DA	F05 / F07	0.55	6.30	3.39	2.76	4.37	3.54	0.75	1/4-20 UNC x 0.51
1-1/4	UT14DA	F05 / F07	0.55	6.30	3.39	2.76	4.37	3.54	0.75	1/4-20 UNC x 0.51
1-1/2	UT14DA	F05 / F07	0.55	6.30	3.39	2.76	4.37	3.54	0.75	1/4-20 UNC x 0.51
2	UT14DA	F05 / F07	0.55	6.30	3.39	2.76	4.37	3.54	0.75	1/4-20 UNC x 0.51

TKD SERIES 3-WAY BALL VALVES

Model UT26

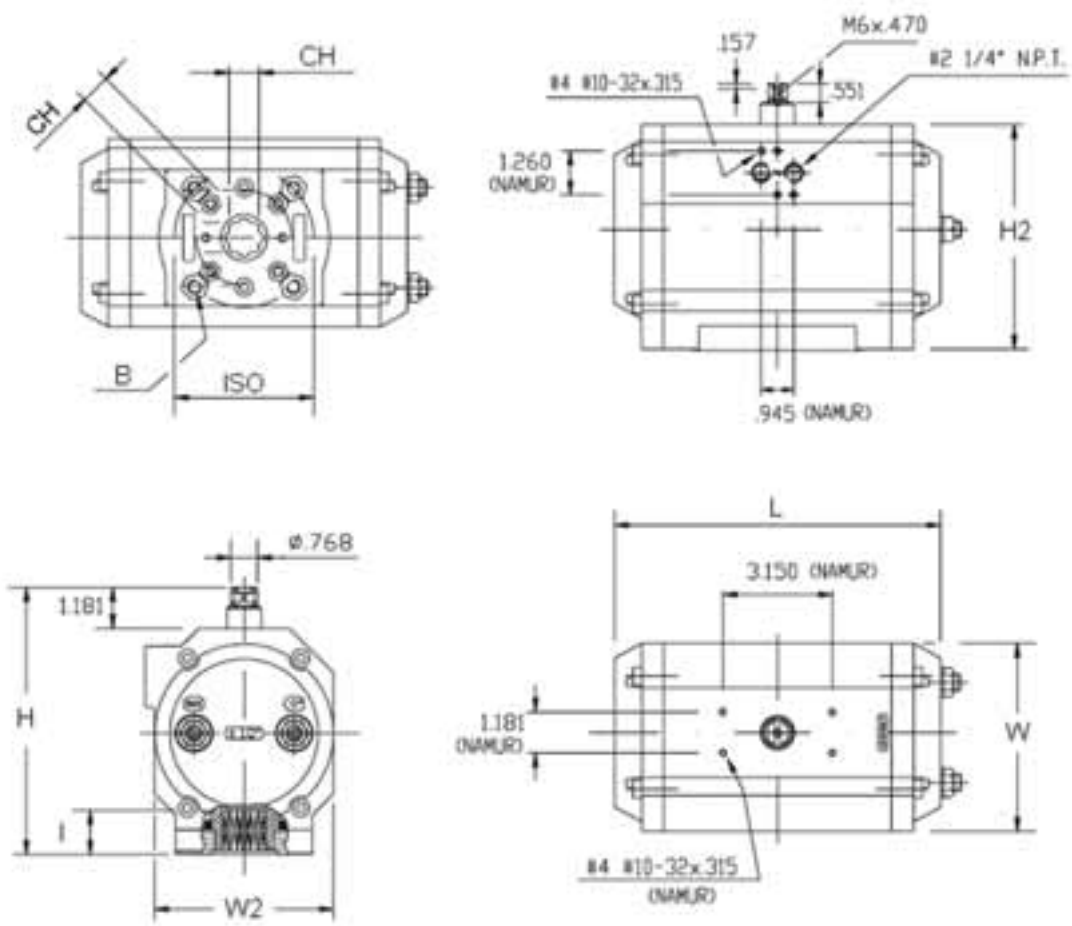

DIMENSIONS (inches)

Valve Size	Spring Return Model	ISO	CH	L	W	W2	H	H2	I	B
1/2	UT11S2	F04	0.43	4.69	2.64	2.09	3.58	2.76	0.49	10-32 UNF x 0.40
3/4	UT14S4	F05 / F07	0.55	6.30	3.39	2.76	4.37	3.54	0.75	1/4-20 UNC x 0.51
1	UT14S4	F05 / F07	0.55	6.30	3.39	2.76	4.37	3.54	0.75	1/4-20 UNC x 0.51
1-1/4	UT19S5	F05 / F07	0.67	6.89	3.98	2.76	5.22	4.39	0.91	5/16-18 UNC x 0.51
1-1/2	UT19S5	F05 / F07	0.67	6.89	3.98	2.76	5.22	4.39	0.91	5/16-18 UNC x 0.51
2	UT26S4	F05 / F07	0.67	9.41	3.78	3.39	5.63	4.41	0.91	5/16-18 UNC x 0.51

TKD SERIES 3-WAY BALL VALVES



Note: Pneumatic actuator performance is based on 80psi available control air pressure.

Actuator Technical Data

Valve Size (inches)	Double Acting Pneumatic	Actuator Model Spring Return Pneumatic	Electric
1/2	UT11DA	UT11S2	VB015
3/4	UT14DA	UT14S4	VB015
1	UT14DA	UT14S4	VB015
1-1/4	UT14DA	UT19S5	VB015
1-1/2	UT14DA	UT19S5	VB030
2	UT14DA	UT26S4	VB030

Pneumatic Actuator Torque Data

Valve Size (inches)	DOUBLE ACTING		SPRING RETURN					
	Model	Torque (in-lbs)	Model	Spring Set (standard)	Spring Torque (in-lbs)		Air Torque (in-lbs)	
					Start	End	Start	End
1/2	UT11DA	125	UT11S2	S2	66	44	81	59
3/4	UT14DA	275	UT14S4	S4	150	107	168	125
1	UT14DA	275	UT14S4	S4	150	107	168	125
1-1/4	UT14DA	275	UT19S5	S5	307	230	270	193
1-1/2	UT14DA	275	UT19S5	S5	307	230	270	193
2	UT14DA	275	UT26S4	S4	392	247	503	358

Pneumatic Actuator Weights and Air Consumption

Valve Size (inches)	DOUBLE ACTING			SPRING RETURN		
	Model	Weight (lbs)	Air Cons. (in ³)	Model	Weight (lbs)	Air Cons. (in ³)
1/2	UT11DA	1.26	13.5	UT11S2	1.44	8.0
3/4	UT14DA	2.62	22.0	UT14S4	3.06	10.8
1	UT14DA	2.62	22.0	UT14S4	3.06	10.8
1-1/4	UT14DA	2.62	22.0	UT19S5	5.16	17.5
1-1/2	UT14DA	2.62	22.0	UT19S5	5.16	17.5
2	UT14DA	2.62	22.0	UT26S4	9.88	30.0

TKD SERIES 3-WAY BALL VALVES

Electric Actuator Dimensions

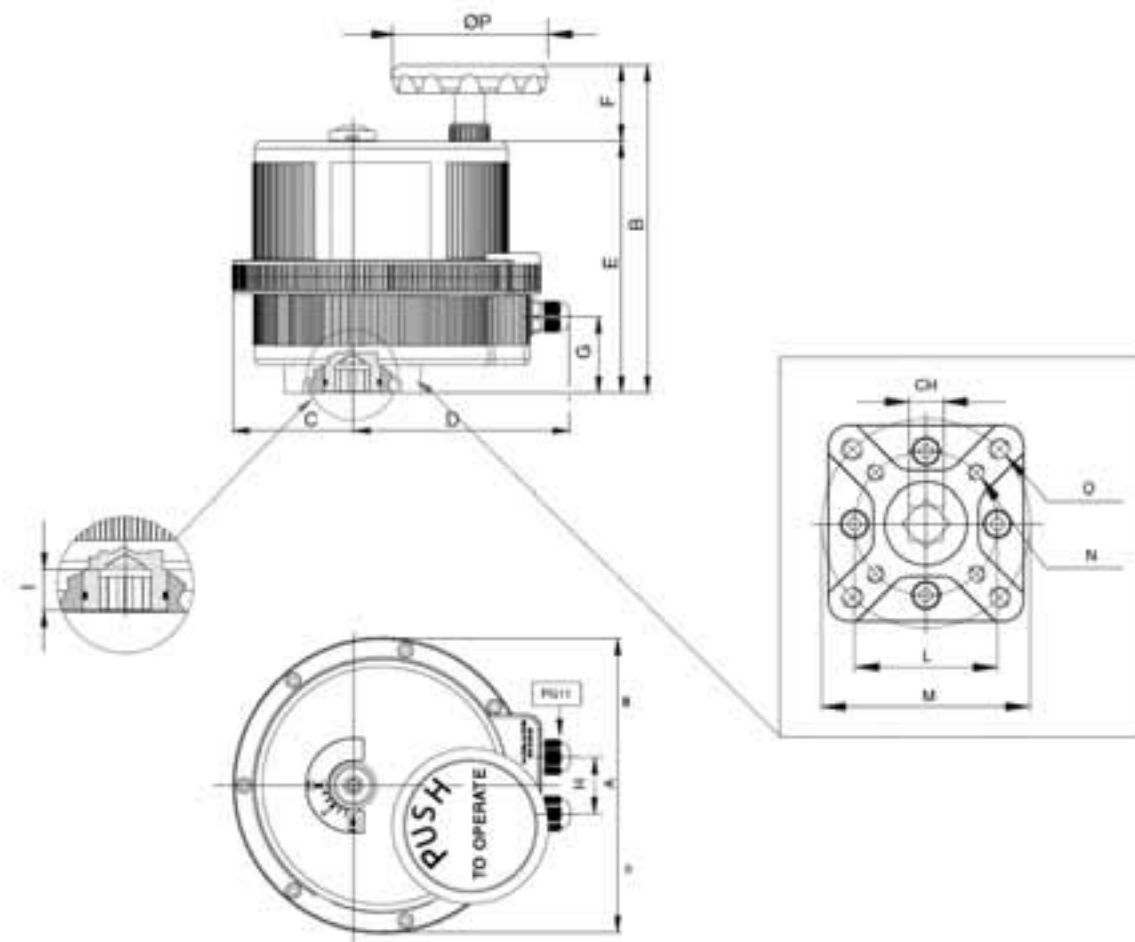

DIMENSIONS (INCHES)

Valve Size	Actuator Model	ISO	CH	A	B	C	D	E	F	G	H	I	L	M	N	O
1/2	VB015	F03 / F05	0.43	4.84	6.28	1.67	4.78	5.67	0.61	4.35	1.26	0.47	1.42	1.97	10-24 UNC x 0.55	1/4-20 UNC x 0.55
3/4	VB015	F03 / F05	0.43	4.84	6.28	1.67	4.78	5.67	0.61	4.35	1.26	0.47	1.42	1.97	10-24 UNC x 0.55	1/4-20 UNC x 0.55
1	VB015	F03 / F05	0.43	4.84	6.28	1.67	4.78	5.67	0.61	4.35	1.26	0.47	1.42	1.97	10-24 UNC x 0.55	1/4-20 UNC x 0.55
1-1/4	VB015	F03 / F05	0.43	4.84	6.28	1.67	4.78	5.67	0.61	4.35	1.26	0.47	1.42	1.97	10-24 UNC x 0.55	1/4-20 UNC x 0.55
1-1/2	VB030	F03 / F05	0.43	6.18	7.39	2.38	5.01	5.75	1.64	1.30	1.42	0.47	1.42	1.97	10-24 UNC x 0.55	1/4-20 UNC x 0.55
2	VB030	F03 / F05	0.43	6.18	7.39	2.38	5.01	5.75	1.64	1.30	1.42	0.47	1.42	1.97	10-24 UNC x 0.55	1/4-20 UNC x 0.55

TKD SERIES 3-WAY BALL VALVES

Electrical Actuator

Model VB015

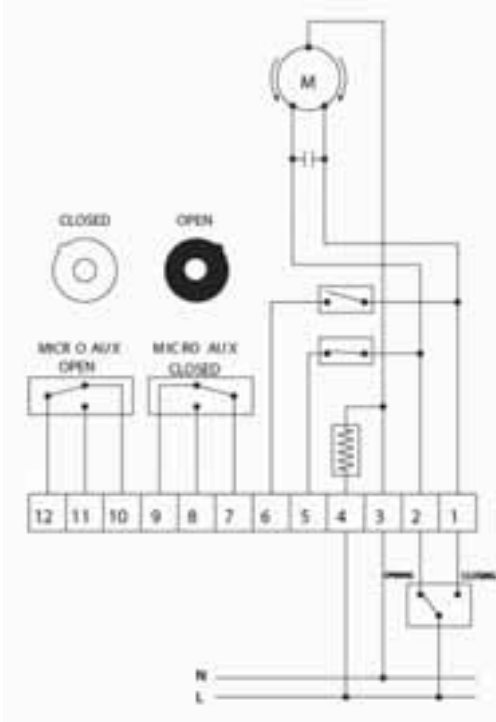

Models VB030

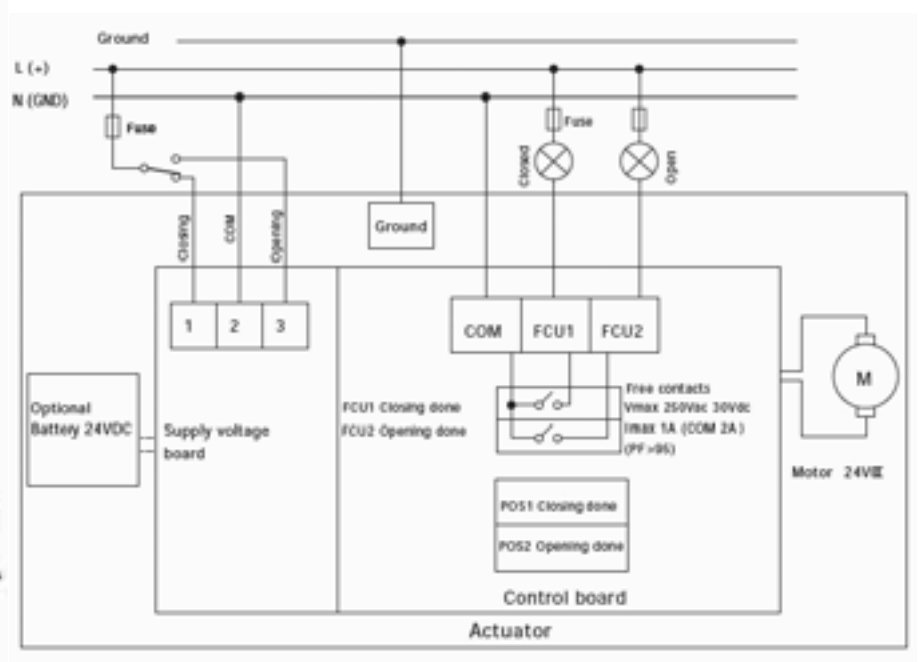

ELECTRICAL ACTUATOR DATA

	Model	VB015	VB030
1	Maximum Working Torque (in-lbs)	133	266
2	Voltage	110 VAC	100 - 240 VAC
3	Absorbed Current	50 mA	0.3 - 0.2 A
4	Absorbed Power	6.6 VA	30 - 48 VA
5	Working Time	25 sec	8 sec
6	Torque Limiter	STD	STD
7	Duty Rating	50%	75%
8	Protection	IP 65-67	IP 65 - 67
9	Rotation	90°	90°
10	Manual Override	STD	STD
11	Position Indicator	STD	STD
12	Working Temperature	-4°F / +131°F	-4°F / +131°F
13	Heater	STD	STD
14	Additional Limit Switches	2 STD	2 STD
15	ISO 5211 Mounting	F03 - F05	F03 - F05
16	Square (in)	0.43	0.43
17	Electrical Connections	PG11	PG11
18	Weight (lbs)	3.09	5.07

TKD SERIES 3-WAY BALL VALVES

Components

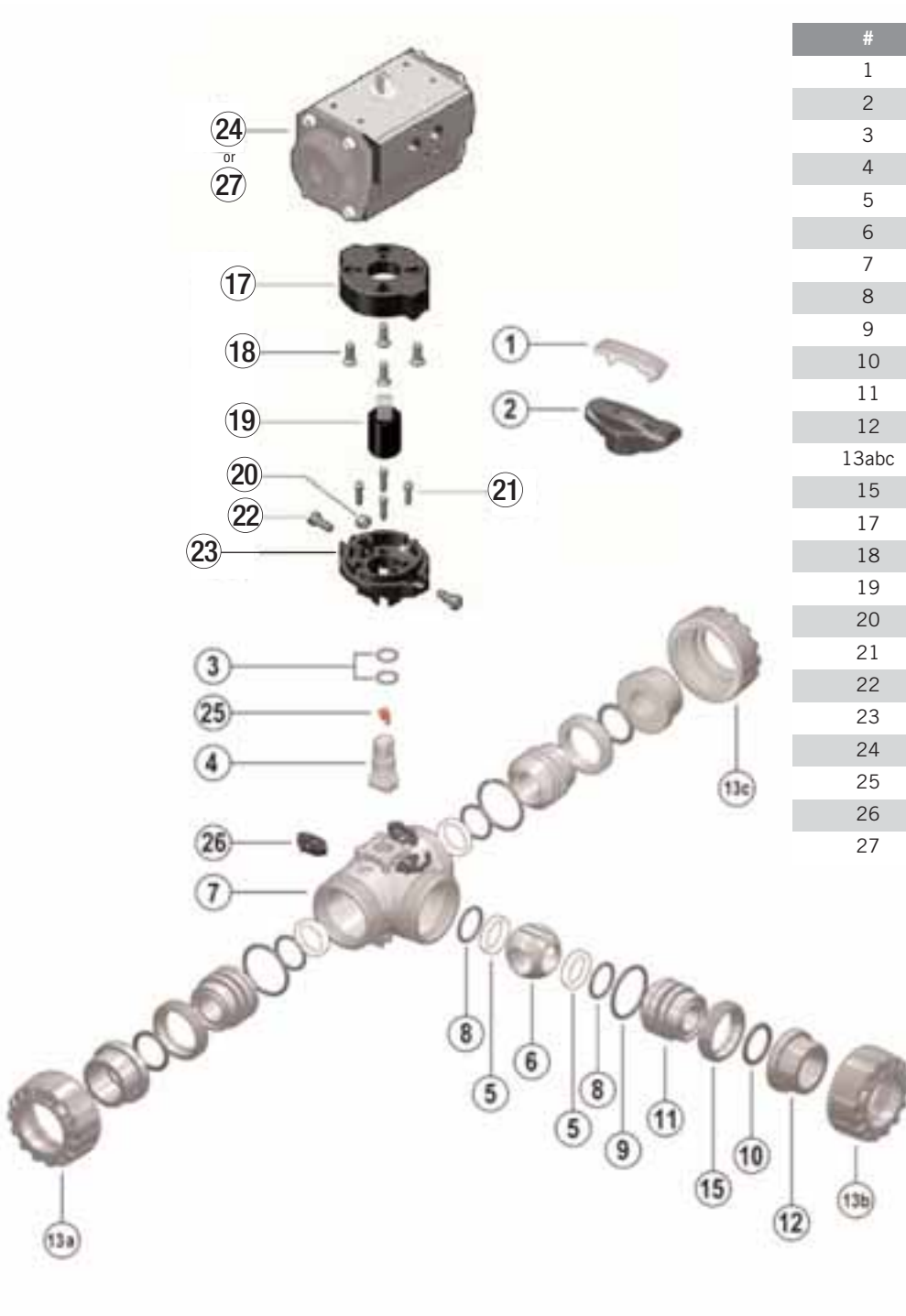

#	Components
1	Insert
2	Handle
3	Stem O-Rings
4	Stem
5	Ball Seat
6	Ball
7	Body
8	Support O-Ring for Ball Seat
9	Radial Seal O-Ring
10	Socket Seal O-Ring
11	Support for Ball Seat
12	End Connector
13abc	Union Nuts
15	Stop Ring
17	Upper Plate
18	Screw
19	Coupling Spindle
20	Nut
21	Screw
22	Screw
23	Lower Plate
24	Pneumatic Actuator
25	Position Indicator
26	Dual Block®
27	Electric Actuator (not shown)

BALL VALVES

TKD SERIES 3-WAY BALL VALVES

Installation Procedures

1. For socket and threaded style connections, remove the union nuts (part #13 on previous page) and slide them onto the pipe. For flanged connections, remove the union nut / flange assemblies from the valve (Figure 1).
2. Please refer to the appropriate connection style subsection:
 - a. For socket style, solvent cement the end connectors (12) onto the pipe ends. For correct joining procedure, please refer to the section entitled, "Joining Methods – Solvent Cementing" in the IPEX Industrial Technical Manual Series, "Volume I: Vinyl Process Piping Systems". Be sure to allow sufficient cure time before continuing with the valve installation.
 - b. For threaded style, thread the end connectors (12) onto the pipe ends. For correct joining procedure, please refer to the section entitled, "Joining Methods – Threading" in the IPEX Industrial Technical Manual Series, "Volume I: Vinyl Process Piping Systems" (Figure 2).
3. All quarter turn automated valves are tested for proper operation before leaving the factory. Adjustment of the seat stop carrier should not be necessary. However, If adjustment is required, remove the insert tool (1) from the handle (2) provided. Line up the moldings on the tool with the slots in the seat supports. Tighten or loosen to the desired position then replace the tool on the handle. For correct alignment of the ball and seat support system, adjustment should begin with the center port.
4. Ensure that the socket o-rings (10) are properly fitted in their grooves then carefully place the valve in the system between the end connections. If anchoring is required, fix the valve to the supporting structure via the integral mounting flange on the bottom of the valve body (7).
5. Tighten the three union nuts. Hand tightening is typically sufficient to maintain a seal for the maximum working pressure. Over-tightening may damage the threads on the valve body and/or the union nut, and may even cause the union nut to crack (Figure 2).
6. Check the installation of the dedicated lock nut device DUAL BLOCK® (26) on the valve body (Figure 3).
7. Connect pneumatic or electric connections according to provided diagrams.
8. Cycle the valve open and close to ensure that the cycling performance is adequate. If adjustment is required, loosen the union nuts, remove the valve from the system, and then continue from Step 3.



Figure 1



Figure 2

Figure 3

TKD SERIES 3-WAY BALL VALVES

Disassembly

1. If removing the valve from an operating system, isolate the valve from the rest of the system. Be sure to depressurize and drain the isolated branch and valve before continuing.
2. If necessary, remove actuator connections and detach the valve from the support structure
3. Unlock the Dual Block® system (Figure 3) by compressing the lever (26). Loosen the three union nuts (13) and drop the valve out of the line. If retaining the socket o-rings (10), take care that they are not lost when removing the valve from the line.
4. Remove the actuator, if necessary, from the valve by removing the screws (22) located horizontally across from each other fastening the upper and lower portions of the actuation pad.
5. To disassemble, rotate the ball to the appropriate position using the provided handle (2).
4. Remove the insert tool (1) from the handle provided, then line up the moldings on the tool with the slots in the seat supports (11). Loosen and remove all three seat supports from the valve body (7).
5. Remove the ball (6) from the valve body while taking care not to score or damage the outer surface.
6. To remove the stem, push it into the valve body from above.
7. Remove the seats (5), backing o-rings (8), and body o-rings (9) from the seat supports.
8. Remove the seat and backing o-ring from the inside of the valve body.
9. Remove the stem o-rings (3).
10. The valve components can now be checked for problems and/or replaced.

Note: It is not necessary to remove the actuator from the valve unless the stem requires servicing or replacement. If possible, leave actuator attached to valve during servicing.

Assembly

Note: Before assembling the valve components, it is advisable to lubricate the o-rings with a water soluble lubricant. Be sure to consult the “IPEX Chemical Resistance Guide” and/or other trusted resources to determine specific lubricant-rubber compatibilities.

1. Properly fit the stem o-rings (3) in the grooves on the stem (4), then insert the stem from the inside of the valve body (7).
2. Line up the markings on the stem with the ports in the valve body.
3. Replace the backing o-ring (8) and seat (5) at the back of the valve body.
4. Insert the ball (6) into the valve body while ensuring that the ports line up with the markings on the stem. Ensure that the actuator and ball position correspond to the same operating position
5. Ensure that all body o-rings (9), backing o-rings, and seats are properly fitted on the three seat supports (11). Starting with the center port, tighten each support into the valve body using the insert tool (1).
6. Replace the actuator, if removed, and affix in position using screws (22) located horizontally across from each other.
7. Properly fit the socket o-rings (10) in their respective grooves.
8. Place the end connectors (12) into the union nuts (13), then thread onto the valve body taking care that the socket o-rings remain properly fitted in their grooves.

This page intentionally
left blank

SECTION FIVE: BUTTERFLY VALVES

FK SERIES BUTTERFLY VALVES

IPEX FK Series Automated Butterfly Valves offer superior strength and chemical resistance in highly corrosive environments and process flow conditions. This versatile industrial valve features double self-lubricating seals, and a special shaped liner and body cavity guaranteeing a bubble tight seal while keeping break-away torque at an absolute minimum. An integral stainless steel lug version provides for full bi-directional operation allowing disassembly of the downstream flange connection without weakening the integrity of the upstream connection to the pressurized line. FK Series Automated Butterfly Valves are part of our complete systems of pipe, valves, and fittings, engineered and manufactured to our strict quality, performance, and dimensional standards.

Standards



ASTM D1784
ASTM D3222
ASTM D4101



ANSI B16.5

Valve Availability

Body Material:	Glass reinforced PP (GFPP)
Disc Material:	PP, PVC, CPVC, ABS, PVDF
Size Range:	1-1/2" through 12"
Pressure:	150psi (1-1/2" TO 10"), 120psi (12")
Seats:	EPDM or Viton® (FKM)
Seals:	EPDM or Viton® (FKM)
Body Style:	Wafer or Lugged
End Connections:	Flanged (ANSI 150)
Actuator Control:	Double Acting Pneumatic, Spring Return Pneumatic, Electric



FK SERIES BUTTERFLY VALVES

Sample Specifications

1.0 Butterfly Valves - FK

1.1 Material

- The valve body shall be made of glass reinforced polypropylene (GRPP) obtained from homopolymer polypropylene (PPH).
- The valve disc shall be made of stabilized PP homopolymer compound, also containing a RAL 7032 pigment, which shall meet or exceed the requirements of Type I Polypropylene according to ASTM D4101.
- The valve disc shall be made of PVC compound which shall meet or exceed the requirements of cell classification 12454 according to ASTM D1784.
- The valve disc shall be made of Corzan® CPVC compound which shall meet or exceed the requirements of cell classification 23447 according to ASTM D1784.
- The valve disc shall be made of virgin, non-regrind PVDF compound which shall meet or exceed the requirements of Table 1 according to ASTM D3222.
- The valve disc shall be made of Duraplus® ABS compound which shall meet or exceed the requirements of cell classification 43234 according to ASTM D3965.
- The valve shaft shall be made of 420 stainless steel.

1.2 Seats

- The disc liner shall be made of EPDM.
- The disc liner shall be made of Viton® (FKM).

1.3 Seals

- The o-ring seals shall be made of EPDM.
- The o-ring seals shall be made of Viton® (FKM).

1.4 All wetted parts of the valves shall comply with standards that are equivalent to NSF Standard 61 for potable water.

2.0 Connections

2.1 Flanged style

- The ANSI 150 flanged connections shall conform to the dimensional standard ANSI B16.5.

3.0 Design Features

- The valve shall be of either wafer or lugged design (specifier must select one).
- The lugged style shall feature permanently integrated stainless steel lugs. No field inserted lugs allowed.
- The shaft shall have standard ISO square dimensions for direct mounting of actuators.

- The disc seat shall be a trapezoidal elastomeric liner and provide a bubble tight seal.
- The liner shall completely isolate the valve body from the process flow.
- The liner shall function as a flange gasket on both sides of the valve.
- The body cavity shall feature special channeling to prevent liner slippage and compression.
- The disc, seats, and seals shall be the only wetted parts.
- Teflon® seated o-ring seals shall prevent the stainless steel shaft from becoming wetted.

3.1 Pressure Rating

- All valves sizes 1-1/2" through 10" shall be rated at 150psi at 73°F.
- All valves sizes 12" shall be rated at 120psi at 73°F.

3.2 Markings

- All valves shall be marked to indicate size, material designation, and manufacturer's name or trade mark.

3.3 Color Coding

- All valves shall be color-coded beige gray.

4.0 All valves shall be by IPEX or approved equal.

5.0 Actuators

- All actuators shall be factory installed by IPEX.
- Pneumatic actuators shall be dual piston rack and pinion design, sized for 80psi control air pressure.
- Electric actuators shall have 110 VAC reversing motors, torque limiters, thermal protection, and NEMA 4 or equivalent housings.

FK SERIES BUTTERFLY VALVES

Dimensions

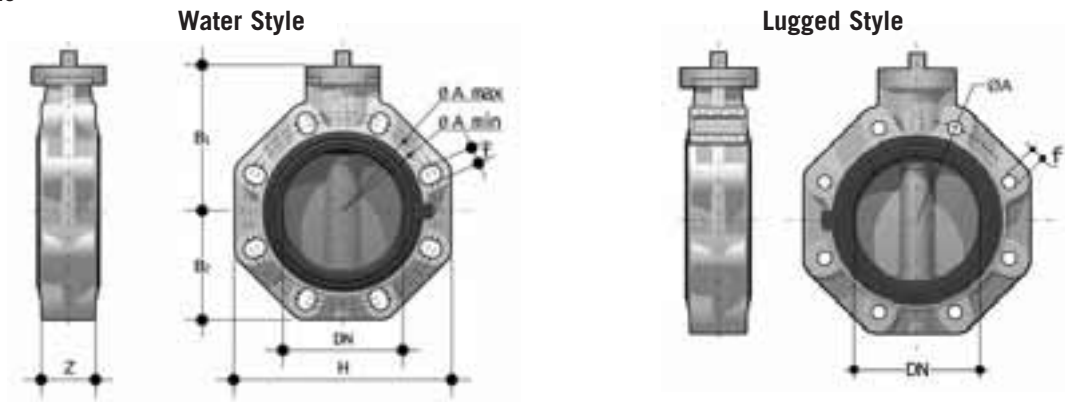

DIMENSIONS (inches)

Size	DN	Z	B1	B2	H	Amin	Amax	f	Alug	flug	# holes
1-1/2	1.57	1.30	4.17	2.36	5.20	3.90	4.29	0.75	3.87	1/2-UNC	4
2	1.97	1.69	4.41	2.76	5.79	4.53	4.94	0.75	4.75	5/8-UNC	4
2-1/2	2.56	1.81	4.69	3.15	6.50	5.04	5.67	0.75	5.50	5/8-UNC	4
3	3.15	1.93	5.24	3.66	7.28	5.71	6.30	0.75	6.00	5/8-UNC	8
4	3.94	2.20	5.79	4.21	8.31	6.50	7.48	0.75	7.50	5/8-UNC	8
5	4.92	2.52	6.57	4.72	9.45	8.03	8.46	0.91	8.50	3/4-UNC	8
6	5.91	2.76	7.09	5.28	10.55	9.06	9.53	0.91	9.50	3/4-UNC	8
8	7.87	2.80	8.94	6.34	12.72	11.02	11.73	0.91	11.75	3/4-UNC	8
10	9.84	4.49	9.76	8.27	15.94	13.19	14.25	1.00	14.25	7/8-UNC	12
12	11.81	4.49	12.01	9.65	18.70	15.35	17.01	1.14	17.00	7/8-UNC	12

Sizes 1-1/2" to 8"

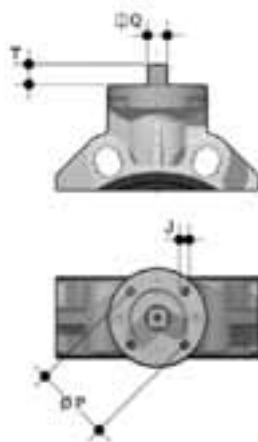

Sizes 10" to 12"

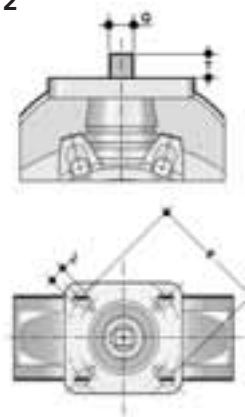

DIMENSIONS (inches)

Size	T	Q	ISO	P	J
1-1/2	0.47	0.43	F05	1.97	0.28
2	0.47	0.43	F05	1.97	0.28
2-1/2	0.47	0.43	F05 / F07	1.97 / 2.76	0.28 / 0.35
3	0.63	0.55	F07	2.76	0.35
4	0.63	0.55	F07	2.76	0.35
5	0.75	0.67	F07	2.76	0.35
6	0.75	0.67	F07	2.76	0.35
8	0.94	0.87	F10	4.02	0.43
10	1.14	1.06	F10 / F12 / F14	4.02 / 4.92 / 5.51	0.43 / 0.51 / 0.67
12	1.14	1.06	F10 / F12 / F14	4.02 / 4.92 / 5.51	0.43 / 0.51 / 0.67

FK SERIES BUTTERFLY VALVES

Pneumatic Actuator Dimensions

Models UT16, UT21, UT26, UT31, UT36, UT41, UT46, UT51, UT61

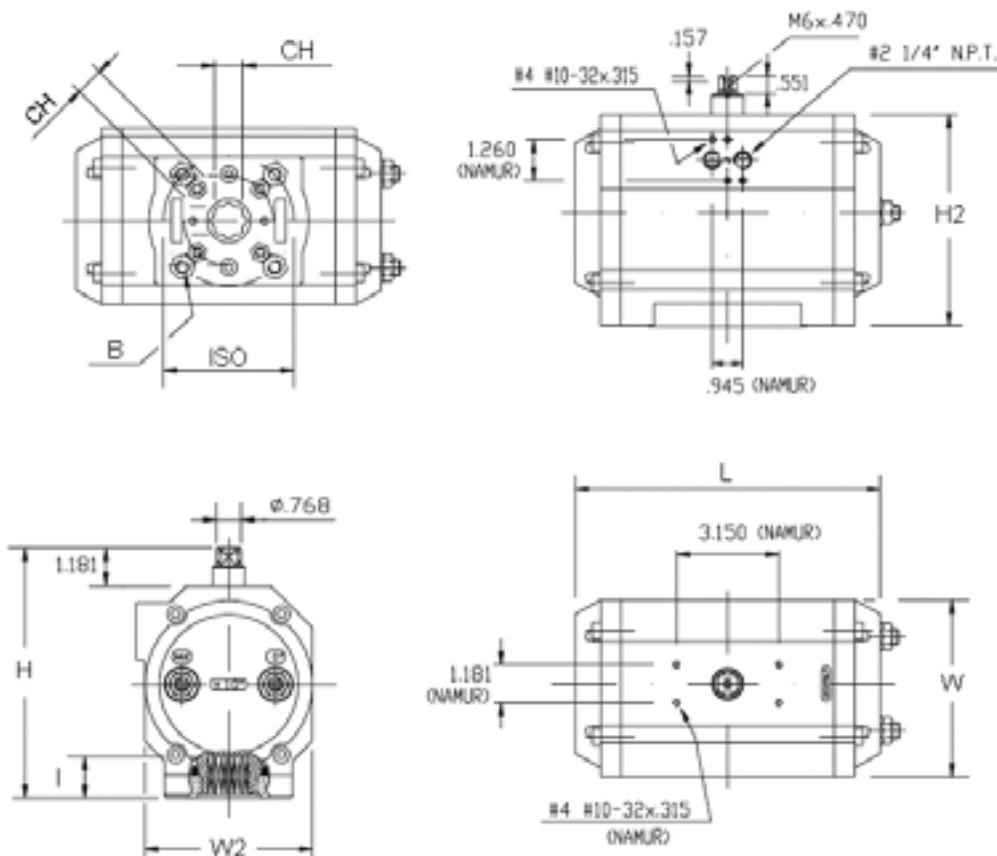

DIMENSIONS (inches)

Valve Size	Double Acting Model	ISO	CH	L	W	W2	H	H2	I	B
1-1/2	UT16DA	F05 / F07	0.55	6.50	3.35	2.76	4.76	3.54	0.75	1/4-20 UNC x 0.51
2	UT16DA	F05 / F07	0.55	6.50	3.35	2.76	4.76	3.54	0.75	1/4-20 UNC x 0.51
2-1/2	UT16DA	F05 / F07	0.55	6.50	3.35	2.76	4.76	3.54	0.75	1/4-20 UNC x 0.51
3	UT21DA	F05 / F07	0.67	6.97	3.78	3.39	5.63	4.41	0.91	5/16-18 UNC x 0.51
4	UT21DA	F05 / F07	0.67	6.97	3.78	3.39	5.63	4.41	0.91	5/16-18 UNC x 0.51
5	UT26DA	F05 / F07	0.67	9.41	3.78	3.39	5.63	4.41	0.91	5/16-18 UNC x 0.51
6	UT31DA	F05 / F07	0.67	9.06	4.45	4.09	6.38	5.16	0.91	5/16-18 UNC x 0.51
8	UT36DA	F07 / F10	0.87	9.69	5.43	5.16	7.72	6.50	1.18	3/8-16 UNC x 0.71
10	UT51DA	F10 / F12	1.06	14.21	7.28	7.17	9.76	8.54	1.46	1/2-13 UNC x 0.79
12	UT51DA	F10 / F12	1.06	14.21	7.28	7.17	9.76	8.54	1.46	1/2-13 UNC x 0.79

DIMENSIONS (inches)

Valve Size	Spring Return Model	ISO	CH	L	W	W2	H	H2	I	B
1-1/2	UT21S5	F05 / F07	0.67	6.97	3.78	3.39	5.63	4.41	0.91	5/16-18 UNC x 0.51
2	UT26S4	F05 / F07	0.67	9.41	3.78	3.39	5.63	4.41	0.91	5/16-18 UNC x 0.51
2-1/2	UT26S4	F05 / F07	0.67	9.41	3.78	3.39	5.63	4.41	0.91	5/16-18 UNC x 0.51
3	UT31S4	F05 / F07	0.67	9.06	4.45	4.09	6.38	5.16	0.91	5/16-18 UNC x 0.51
4	UT36S4	F07 / F10	0.87	9.69	5.43	5.16	7.72	6.50	1.18	3/8-16 UNC x 0.71
5	UT41S4	F07 / F10	0.87	11.42	5.43	5.16	7.72	6.50	1.18	3/8-16 UNC x 0.71
6	UT46S4	F07 / F10	0.87	13.82	5.95	5.75	8.19	6.97	1.18	3/8-16 UNC x 0.71
8	UT51S4	F10 / F12	1.06	14.21	7.28	7.17	9.76	8.54	1.46	1/2-13 UNC x 0.79
10	UT61S5	F14	1.42	17.48	9.25	9.13	12.01	10.79	1.97	5/8-11 UNC x 0.98
12	UT61S5	F14	1.42	17.48	9.25	9.13	12.01	10.79	1.97	5/8-11 UNC x 0.98

FK SERIES BUTTERFLY VALVES

Electric Actuator Dimensions

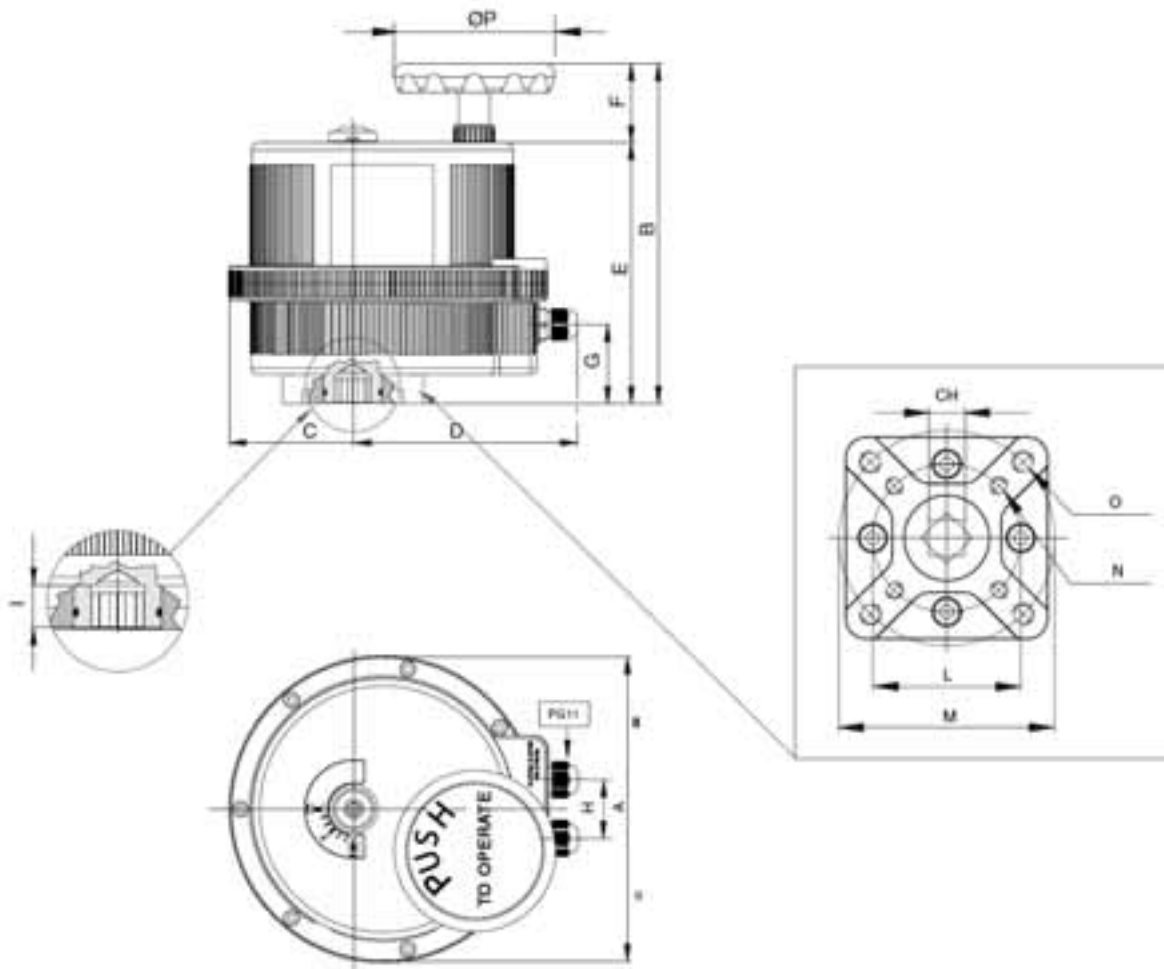

DIMENSIONS (inches)

Valve Size	Actuator Model	ISO	CH	A	B	C	D	E	F	G	H	I	L	M	N	O
1-1/2	VB015	F03 / F05	0.43	4.84	6.28	1.67	4.78	5.67	0.61	4.35	1.26	0.47	1.42	1.97	10-24 UNC x 0.55	1/4-20 UNC x 0.55
2	VB030	F03 / F05	0.43	6.18	7.39	2.38	5.01	5.75	1.64	1.30	1.42	0.47	1.42	1.97	10-24 UNC x 0.55	1/4-20 UNC x 0.55
2-1/2	VB030	F03 / F05	0.43	6.18	7.39	2.38	5.01	5.75	1.64	1.30	1.42	0.47	1.42	1.97	10-24 UNC x 0.55	1/4-20 UNC x 0.55
3	VB060	F05 / F07	0.55	7.28	8.46	2.66	5.77	6.81	1.65	2.01	1.42	0.63	1.97	2.76	1/4-20 UNC x 0.67	5/16-18 UNC x 0.67
4	VB060	F05 / F07	0.55	7.28	8.46	2.66	5.77	6.81	1.65	2.01	1.42	0.63	1.97	2.76	1/4-20 UNC x 0.67	5/16-18 UNC x 0.67
5	VB110	F07 / F10	0.67	8.19	9.14	3.31	6.02	7.01	2.13	2.13	1.57	0.75	2.76	4.02	5/16-18 UNC x 0.79	3/8-16 UNC x 0.79
6	VB110	F07 / F10	0.67	8.19	9.14	3.31	6.02	7.01	2.13	2.13	1.57	0.75	2.76	4.02	5/16-18 UNC x 0.79	3/8-16 UNC x 0.79
8	VB190	F07 / F10	0.87	8.19	9.14	3.31	6.02	7.01	2.13	2.13	1.57	0.75	2.76	4.02	5/16-18 UNC x 0.79	3/8-16 UNC x 0.79

FK SERIES BUTTERFLY VALVES



Note: Pneumatic actuator performance is based on 80psi available control air pressure.

Actuator Technical Data

Valve Size (inches)	Double Acting Pneumatic	Spring Return Pneumatic	Electric
1-1/2	UT16DA	UT21S5	VB015
2	UT16DA	UT26S4	VB030
2-1/2	UT16DA	UT26S4	VB030
3	UT21DA	UT31S4	VB060
4	UT21DA	UT36S4	VB060
5	UT26DA	UT41S4	VB110
6	UT31DA	UT46S4	VB110
8	UT36DA	UT51S4	VB190
10	UT51DA	UT61S5	-
12	UT51DA	UT61S5	-

Pneumatic Actuator Torque Data

Valve Size (inches)	DOUBLE ACTING		SPRING RETURN					
	Model	Torque (in-lbs)	Model	Spring Set (standard)	Spring Torque (in-lbs)		Air Torque (in-lbs)	
					Start	End	Start	End
1-1/2	UT16DA	275	UT21S5	S5	307	230	270	193
2	UT16DA	275	UT26S4	S4	392	247	503	358
2-1/2	UT16DA	275	UT26S4	S4	392	247	503	358
3	UT21DA	500	UT31S4	S4	502	374	626	498
4	UT21DA	500	UT36S4	S4	824	614	986	776
5	UT26DA	750	UT41S4	S4	1011	741	1259	989
6	UT31DA	1000	UT46S4	S4	1779	1120	2005	1346
8	UT36DA	1600	UT51S4	S4	2203	1738	2762	2297
10	UT51DA	4500	UT61S5	S5	5366	4277	4823	3734
12	UT51DA	4500	UT61S5	S5	5366	4277	4823	3734

Pneumatic Actuator Weights and Air Consumption

Valve Size (inches)	DOUBLE ACTING			SPRING RETURN		
	Model	Weight (lbs)	Air Cons. (in3)	Model	Weight (lbs)	Air Cons. (in3)
1-1/2	UT16DA	4.03	25.6	UT21S5	7.16	18.1
2	UT16DA	4.03	25.6	UT26S4	9.88	30.0
2-1/2	UT16DA	4.03	25.6	UT26S4	9.88	30.0
3	UT21DA	6.33	44.4	UT31S4	12.28	40.6
4	UT21DA	6.33	44.4	UT36S4	19.88	75.0
5	UT26DA	8.82	68.7	UT41S4	23.61	100.0
6	UT31DA	10.67	88.9	UT46S4	33.11	115.6
8	UT36DA	16.71	153.1	UT51S4	49.89	181.3
10	UT51DA	39.24	425.0	UT61S5	101.19	343.8
12	UT51DA	39.24	425.0	UT61S5	101.19	343.8

FK SERIES BUTTERFLY VALVES

Electrical Actuator

Model VB015

Models VB030, VB060, VB110, VB190

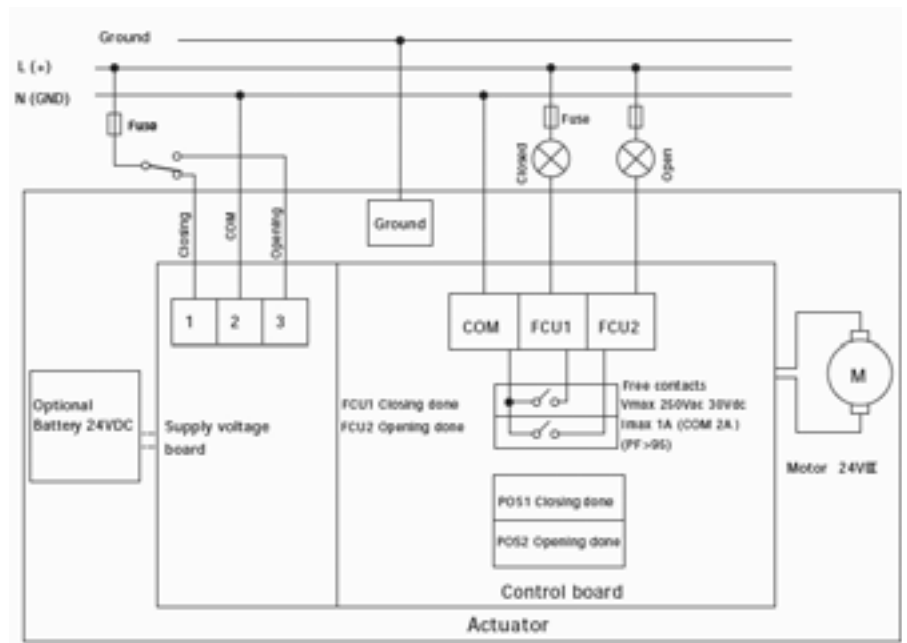
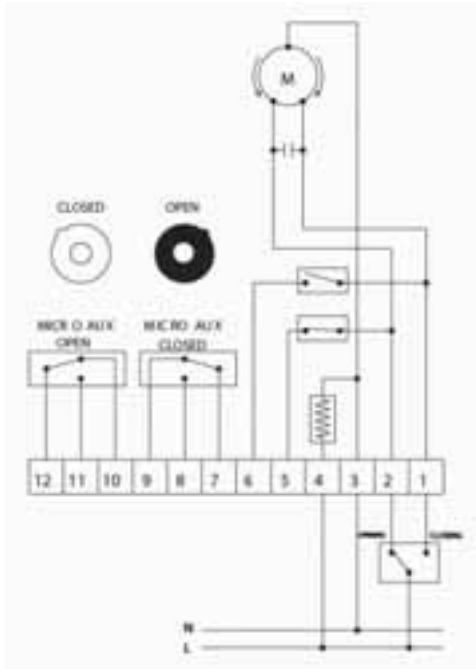

ELECTRICAL ACTUATOR DATA

Model	VB015	VB030	VB060	VB110	VB190
1 Maximum Working Torque (in-lbs)	133	266	530	975	1680
2 Voltage	110 VAC	100-240 VAC	100-240 VAC	100-240 VAC	100-240 VAC
3 Absorbed Current	50 mA	0.3-0.2 A	0.6-0.3 A	0.6-0.3 A	0.6-0.3 A
4 Absorbed Power	6.6 VA	30-48 VA	60-72 VA	60-72 VA	60-72 VA
5 Working Time	25 sec	8 sec	9 sec	27 sec	27 sec
6 Torque Limiter	STD	STD	STD	STD	STD
7 Duty Rating	50%	75%	75%	75%	75%
8 Protection	IP 65-67	IP 65-67	IP 65-67	IP 65-67	IP 65-67
9 Rotation	90°	90°	90°	90°	90°
10 Manual Override	STD	STD	STD	STD	STD
11 Position Indicator	STD	STD	STD	STD	STD
12 Working Temperature	-4°F / +131°F	-4°F / +131°F	-4°F / +131°F	-4°F / +131°F	-4°F / +131°F
13 Heater	STD	STD	STD	STD	STD
14 Additional Limit Switches	2 STD	2 STD	2 STD	2 STD	2 STD
15 ISO 5211 Mounting	F03 F05	F03 F05	F05 F07	F07 F10	F07 F10
16 Square (in)	0.43	0.43	0.55	0.67	0.87
17 Electrical Connections	PG11	PG11	PG11	PG11	PG11
18 Weight (lbs)	3.09	5.07	7.28	10.8	10.8

FK SERIES BUTTERFLY VALVES

Components

Sizes 1-1/2" to 8"

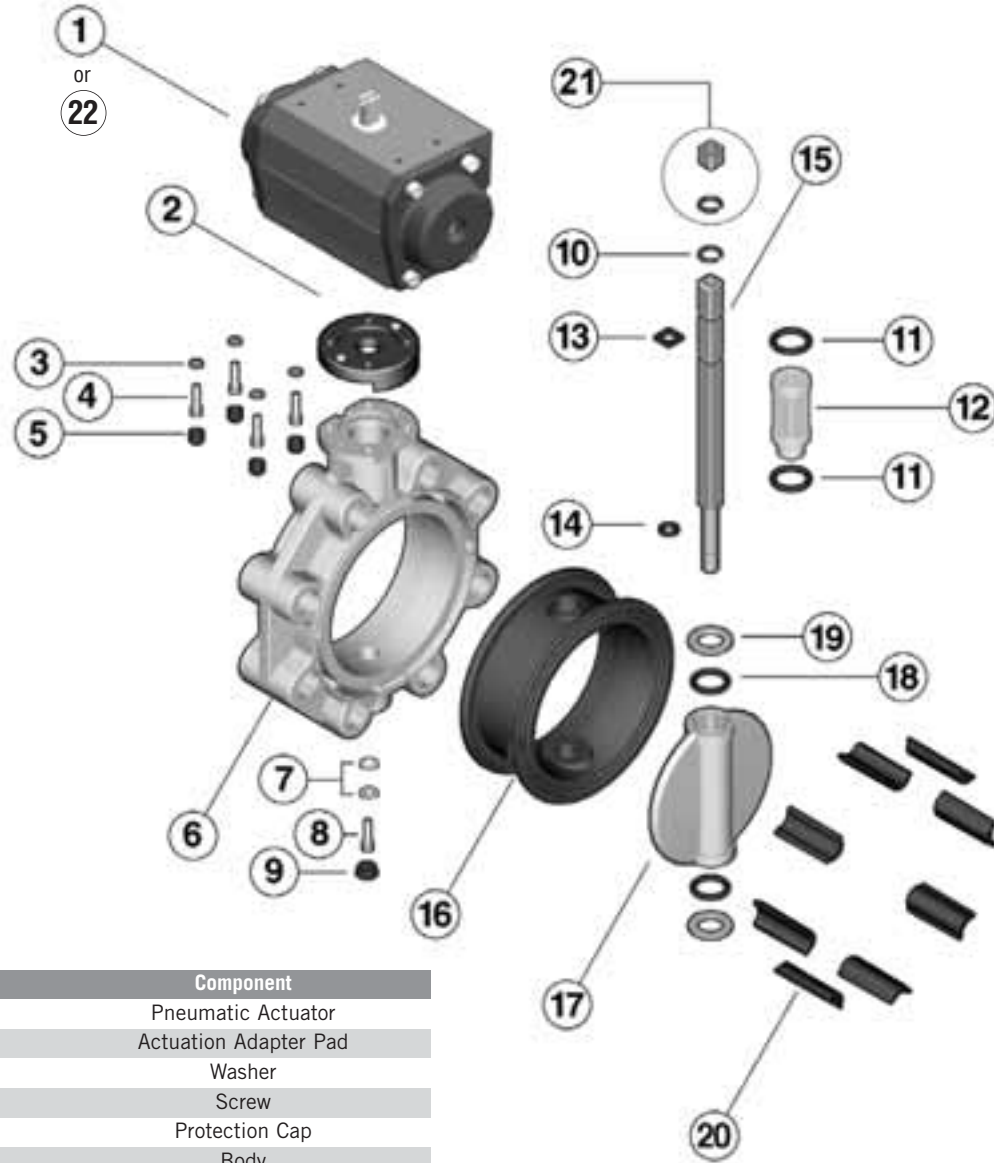

#	Component
1	Pneumatic Actuator
2	Actuation Adapter Pad
3	Washer
4	Screw
5	Protection Cap
6	Body
7	Washer
8	Screw
9	Protection Cap
10	Seeger Ring
11	Bush O-Ring
12	Bush
13	Shaft O-Ring
14	Shaft O-Ring
15	Shaft
16	Primary Liner
17	Disc
18	Disc O-Ring
19	Anti-Friction Ring
20	Centering Inserts
21	Reduction Sleeve
22	Electric Actuator (not shown)

FK SERIES BUTTERFLY VALVES

Components
Sizes 10" to 12"

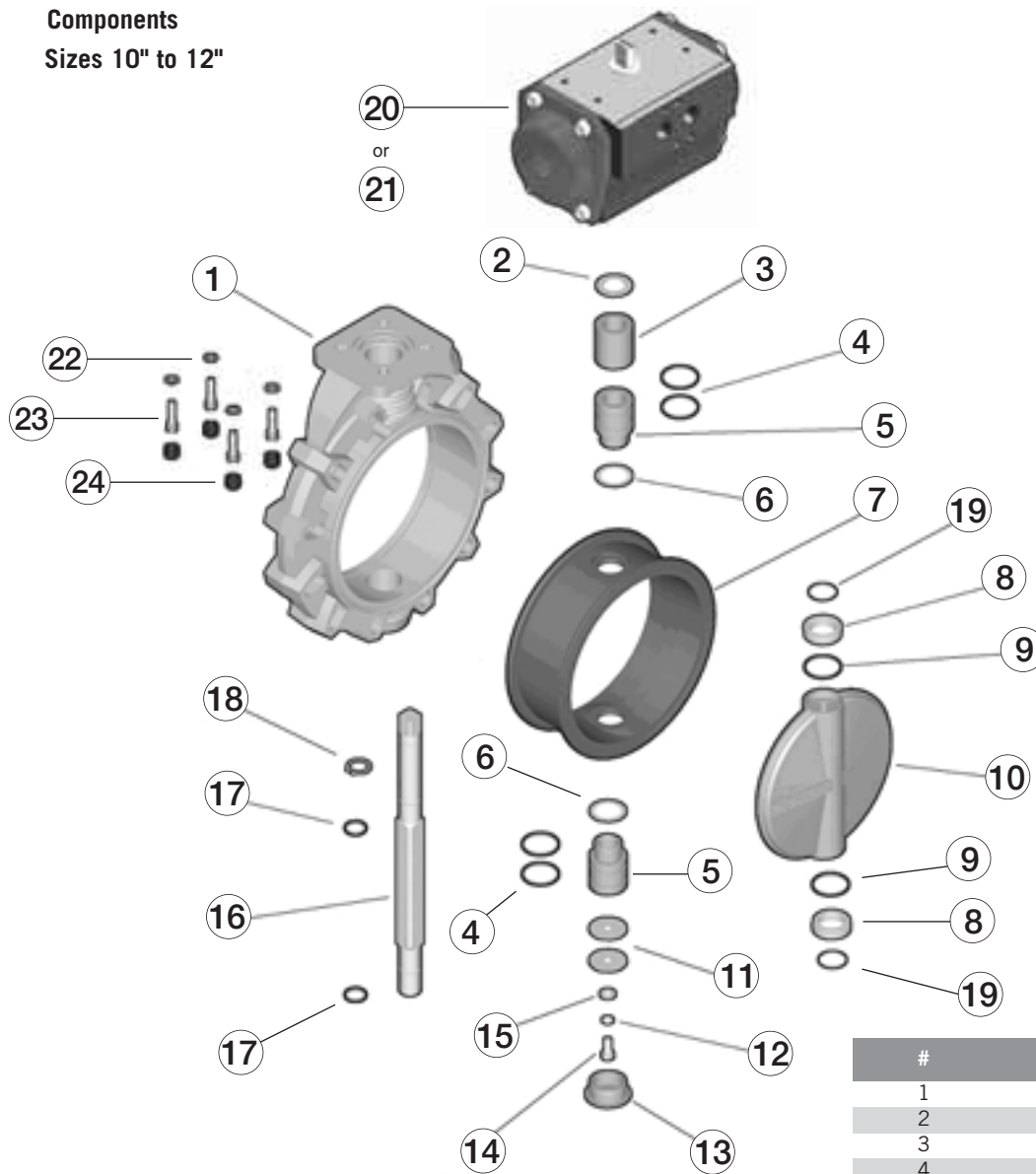

#	Component
1	Body
2	Washer
3	Bushing
4	Bushing O-Ring
5	Bushing for O-Ring
6	Washer
7	Primary Liner
8	Anti-Friction Ring
9	Disc O-Ring
10	Disc
11	Washer
12	Washer
13	Cap
14	Screw
15	Washer
16	Shaft
17	Shaft O-Ring
18	Retaining Ring
19	O-Ring
20	Pneumatic Actuator
21	Electric Actuator (not shown)
22	Washer
23	Screw
24	Protection Cap

FK SERIES BUTTERFLY VALVES

Installation

1. For non-lugged style sizes 1-1/2" through 8", push the inserts (27) into the body holes according to the position chart below.
2. Ensure that the length of the bolts is sufficient for the size of valve being installed. Due to the varying designs of plastic flanges, there is no recommended minimum length. However, a length that results in at least 5 exposed threads on each side should be sufficient.

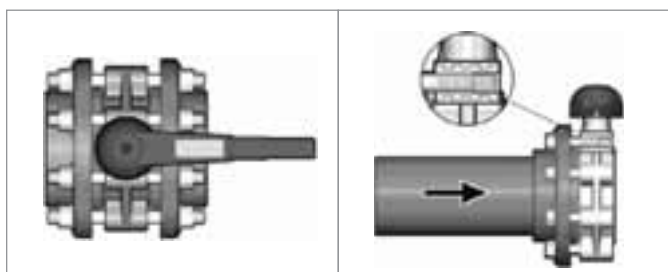

3. Please refer to the appropriate application sub-section:
 - a. For typical inline installation, ensure that the disc is in the partially closed position then carefully insert the valve into the piping system between the two flanges. Insert the bolts, washers, and nuts (if necessary), then hand tighten. Take care to properly line up the valve and flanges as any misalignment may cause leakage.
 - b. For lugged version end of line installation, ensure that the disc is in the partially closed position then carefully position the valve on the flange. Insert the bolts, and washers, then hand tighten. Take care to properly line up the valve and flange as any misalignment may cause leakage.

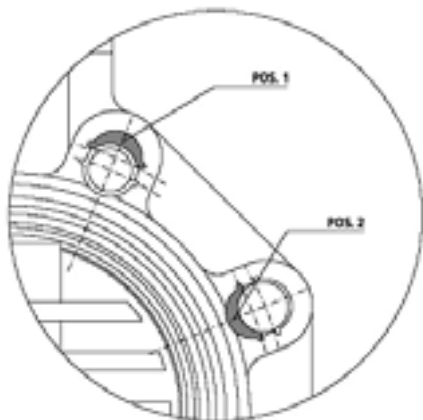

5. Connect pneumatic or electric connections according to provided diagrams.



Size (inches)	ANSI 150 Insert Position	Nominal Bolt Torque (ft-lbs)
1-1/2	POS 1	7
2	-	9
2-1/2	POS 2	11
3	POS 2	13
4	POS 2	15
5	POS 2	26
6	POS 2	30
8	POS 2	41
10	-	52
12	-	52

5. To avoid damage to the primary gasket, cycle the valve to the open position before tightening the bolts. For correct joining procedure, please refer to the section entitled, "Joining Methods – Flanging" in the IPEX Industrial Technical Manual Series, "Volume I: Vinyl Process Piping Systems". The bolts should be tightened in an even pattern to the nominal torque in the table below. These torque ratings are sufficient to maintain a watertight seal at the maximum rated operating pressure.

Note: If the process media is dirty or contains suspended particles, it is advisable to install the valve in an orientation in which the shaft is not vertical (see diagrams). Over time, particles may collect at the bottom of the valve posing a threat to the seal between the disc, liner, and shaft.

Note: All quarter turn automated valves are tested for proper operation before leaving the factory.

FK SERIES BUTTERFLY VALVES

Disassembly

1. If removing the valve from an operating system, isolate the valve from the rest of the system. Be sure to depressurize and drain the isolated branch before continuing. It is recommended that all actuators be de-activated before servicing the valve to avoid injury.
2. Cycle the valve to a partially open position then loosen each bolt holding the valve to the pipe flange(s). Please refer to the section entitled, "Joining Methods – Flanging" in the IPEX Industrial Technical Manual Series, "Volume I: Vinyl Process Piping Systems" for a recommended bolt tightening pattern diagram. Follow the same pattern when disassembling the flanged joint(s) then carefully remove the valve from the line.

Sizes 1-1/2" to 8":

3. Loosen and remove the bolts, washers and protection caps fixed to the actuator (3, 4, & 5). Carefully remove the actuator and the pad (2) from the valve taking care not to damage the stem.
4. Remove the cap (9) then loosen and remove the screw (8) and washer (7) from the base of the valve body.
5. Carefully pull the shaft (15) out of the valve body then remove the disc (17).
6. Remove the primary liner (16) from the valve body.
7. Remove the nylon bushing (12) and o-rings (11) from the valve body (sizes 2-1/2" to 8").
8. Remove the disc anti-friction rings (19), and o-rings (18, sizes 2-1/2" to 8").
9. Remove the retaining ring (10, sizes 2-1/2" to 8") and o-rings (13, 14) from the shaft.
10. The valve components can now be checked for problems and/or replaced.

Sizes 10" to 12":

3. Loosen and remove the bolts, washers and protection caps fixed to the actuator (22, 23 & 24). Carefully remove the actuator from the valve taking care not to damage the stem.
4. Remove the cap (13) then loosen and remove the screw (14) and washers (11, 12 & 15) from the base of the valve body (1).
5. Carefully pull the shaft (16) out of the valve body then remove the disc (10).
6. Remove the primary liner (7) from the valve body.
7. Remove the upper and lower bushings (3, 5), washers (2, 6), and o-rings (4) from the valve body.
8. Remove the disc anti-friction rings (8) and o-rings (9, 19).
9. Remove the retaining ring (18) and o-rings (17) from the shaft.
10. The valve components can now be checked for problems and/or replaced.

FK SERIES BUTTERFLY VALVES

Assembly

Note: Before assembling the valve components, it is advisable to lubricate the o-rings with a water soluble lubricant. Be sure to consult the "IPEX Chemical Resistance Guide" and/or other trusted resources to determine specific lubricant-rubber compatibilities.

Sizes 1-1/2" to 8":

1. Insert the primary liner (16) into the valve body (6). Ensure that the proper holes line up with those on the body.
2. Properly fit the o-rings (11) on the nylon bushing (12) (sizes 2-1/2" to 8") then insert the Teflon washer and bushing into the valve body from above.
3. Properly fit the disc o-rings (18, sizes 2-1/2" to 8") and anti-friction rings (19) on the disc (17), then insert into the valve liner taking care to center the holes.
4. Properly fit the o-rings (13, 14) and retaining ring (10, sizes 2-1/2" to 8") in their grooves on the shaft (15), then carefully insert into the valve body from above.
5. Fasten the shaft at the base of the valve body using the screw (8) and washer (7). Affix the cap (9) over the bolt.
6. Place the spacer pad (2) on the valve body.
7. Carefully place the actuator on the stem, lining up the holes. Fasten using the necessary bolts, washers and protection caps (3, 4 & 5). Ensure that the actuator and disk position correspond to the same operating position

Sizes 10" to 12":

1. Insert the primary liner (7) into the valve body (1). Ensure that the proper holes line up with those on the body.
2. Properly fit the o-rings (4) on the upper and lower bushings (3, 5) then insert into the valve body from above and below along with the washers (2, 6).
3. Properly fit the disc o-rings (9, 19) and anti-friction rings (8) on the disc (10), then insert into the valve liner taking care to center the holes.
4. Properly fit the o-rings (17) and retaining ring (18) in their grooves on the shaft (16), then carefully insert into the valve body from above.
5. Fasten the shaft at the base of the valve body using the screw (14) and washers (11, 12, and 15). Affix the cap (13) over the bolt.
6. Carefully place the actuator on the stem, lining up the holes. Fasten using the necessary bolts, washers and protection cap (22, 23 & 24). Ensure that the actuator and disk position correspond to the same operating position

FE SERIES BUTTERFLY VALVES

IPEX FE Series Automated Butterfly Valves incorporate many features of our industrial FK valve, yet the all PVC construction and EPDM liner make this valve the perfect choice for water and light industrial applications. This versatile valve features double self-lubricating seals, and a special shaped liner and body cavity guaranteeing a bubble tight seal while keeping break-away torque at an absolute minimum. Inserting stainless steel lugs into special molded features in the body allows for end of line installation. FE Series Automated Butterfly Valves are part of our complete systems of pipe, valves, and fittings, engineered and manufactured to our strict quality, performance, and dimensional standards.

Standards



ASTM D1784



ANSI B16.5

Valve Availability

Body Material:	PVC
Disc Material:	PVC
Size Range:	1-1/2" through 12"
Pressure:	232psi (1-1/2" to 2"), 150psi (2-1/2" to 8"), 75psi (10" to 12")
Seats:	EPDM
Seals:	EPDM
Body Style:	Wafer
End Connections:	Flanged (ANSI 150)
Actuator Control:	Double Acting Pneumatic, Spring Return Pneumatic, Electric



FE SERIES BUTTERFLY VALVES

Sample Specification

1.0 Butterfly Valves – FE

1.1 Material

- The valve body and disc shall be made of PVC compound which shall meet or exceed the requirements of cell classification 12454 according to ASTM D1784.
- The valve shaft shall be made of zinc plated steel (sizes 1-1/2" to 8").
- The valve shaft shall be made of 420 stainless steel (sizes 10" and 12").

1.2 Seats

- The disc liner shall be made of EPDM

1.3 Seals

- The o-ring seals shall be made of EPDM.

1.4 All wetted parts of the valves shall comply with standards that are equivalent to NSF Standard 61 for potable water.

2.0 Connections

2.1 Flanged style

- The ANSI 150 flanged connections shall conform to the dimensional standard ANSI B16.5.

3.0 Design Features

- The valve shall be of wafer design.
- The shaft shall have standard ISO square dimensions for direct mounting of actuators.
- The disc seat shall be a trapezoidal elastomeric liner and provide a bubble tight seal.
- The liner shall completely isolate the valve body from the process flow.
- The liner shall function as a flange gasket on both sides of the valve.
- The body cavity shall feature special channeling to prevent liner slippage and compression.
- The disc, seats, and seals shall be the only wetted parts.
- Teflon® seated o-ring seals shall prevent the shaft from becoming wetted.

3.1 Pressure Rating

- All valves sizes 2-1/2" through 8" shall be rated at 150psi at 73°F.
- All valves sizes 10" through 12" shall be rated at 75psi at 73°F.

3.2 Markings

- All valves shall be marked to indicate size, material designation, and manufacturer's name or trade mark.

3.3 Color Coding

- All valves shall be color-coded dark gray.

4.0 All valves shall be Xirtec®140 by IPEX or approved equal.

5.0 Actuators

- All actuators shall be factory installed by IPEX.
- Pneumatic actuators shall be dual piston rack and pinion design, sized for 80psi control air pressure.
- Electric actuators shall have 110 VAC reversing motors, torque limiters, thermal protection, and NEMA 4 or equivalent housings.

FE SERIES BUTTERFLY VALVES

Dimensions

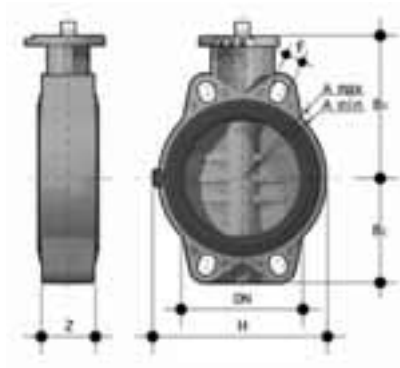

DIMENSIONS (inches)

Size	DN	Z	B2	B3	H	Amin	Amax	f	# holes	Pattern
1-1/2	1.57	1.30	2.36	4.17	5.20	3.68	4.29	0.75	4	square
2	1.97	1.69	2.76	4.45	5.79	4.25	4.88	0.75	4	square
2-1/2	2.56	1.81	3.15	4.84	6.50	5.04	5.67	0.75	4	square
3	3.15	1.93	3.54	5.59	5.12	5.71	6.26	0.75	4	rectangular
4	3.94	2.20	4.13	5.98	5.91	6.50	7.48	0.75	4	rectangular
5	4.92	2.52	4.76	6.93	7.28	8.03	8.46	0.91	4	rectangular
6	5.91	2.76	5.20	7.44	8.27	9.06	9.53	0.91	4	rectangular
8	7.87	2.80	6.34	8.46	12.80	11.02	11.73	0.91	8	square
10	9.84	4.49	8.27	9.76	15.94	14.25	14.25	1.00	12	square
12	11.81	4.49	9.65	12.01	18.70	17.00	17.00	1.00	12	square

Sizes 1-1/2" to 8"

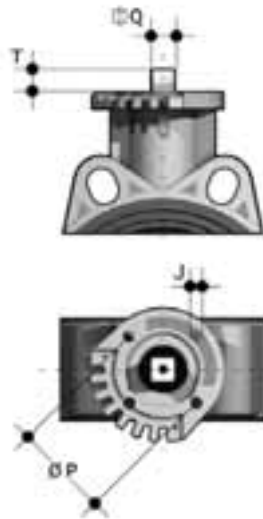

Sizes 10" and 12"

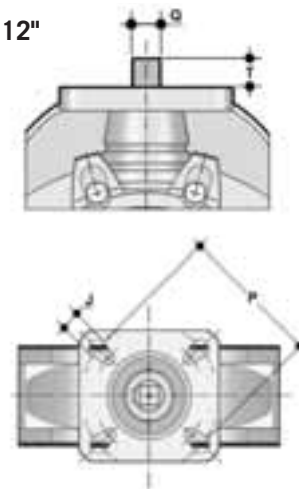

DIMENSIONS (inches)

Size	T	Q	ISO	P	J
1-1/2	0.47	0.43	F05	1.97	0.28
2	0.47	0.43	F05	1.97	0.28
2-1/2	0.47	0.43	F05 / F07	1.97 / 2.76	0.28 / 0.35
3	0.63	0.55	F07	2.76	0.35
4	0.63	0.55	F07	2.76	0.35
5	0.75	0.67	F07	2.76	0.35
6	0.75	0.67	F07	2.76	0.35
8	0.94	0.87	F10	4.02	0.43
10	0.94	0.87	F10 / F12 / F14	4.02 / 4.92 / 5.51	0.43 / 0.51 / 0.67
12	0.94	0.87	F10 / F12 / F14	4.02 / 4.92 / 5.51	0.43 / 0.51 / 0.67

FE SERIES BUTTERFLY VALVES

Pneumatic Actuator Dimensions

Models UT16, UT21, UT26, UT31, UT36, UT41, UT46, UT51, UT61

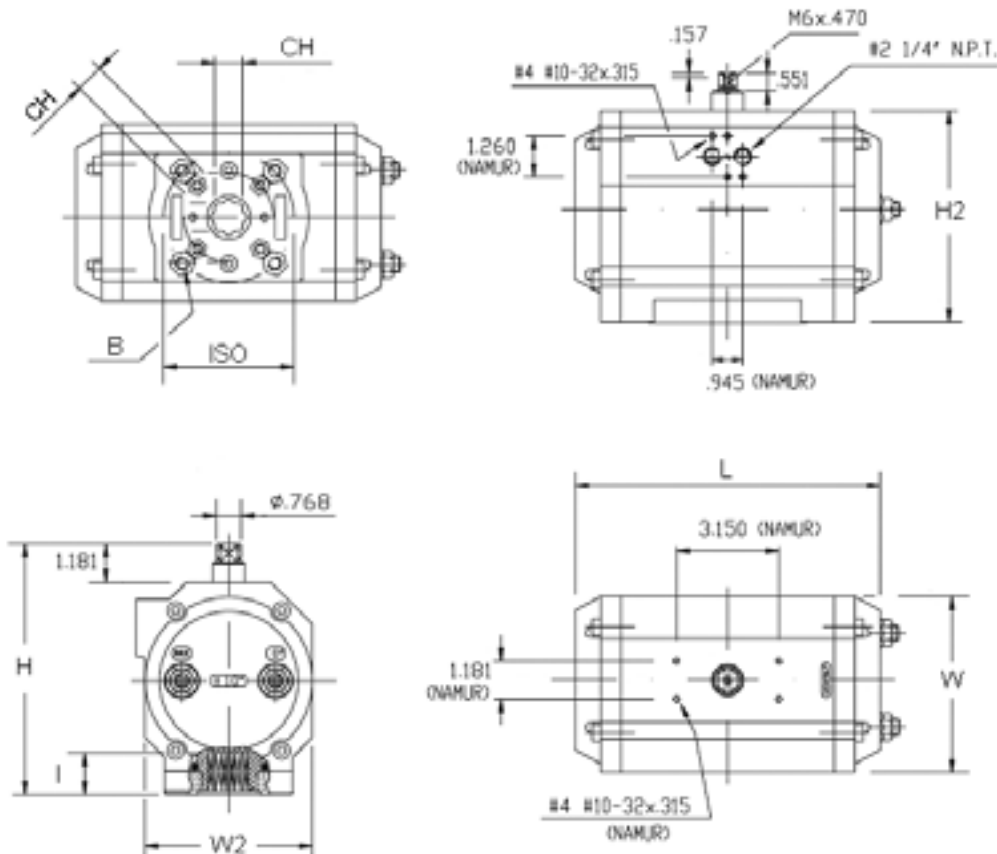

DIMENSIONS (inches)

Valve Size	Double Acting Model	ISO	CH	L	W	W2	H	H2	I	B
1-1/2	UT16DA	F05 / F07	0.55	6.50	3.35	2.76	4.76	3.54	0.75	1/4-20 UNC x 0.51
2	UT16DA	F05 / F07	0.55	6.50	3.35	2.76	4.76	3.54	0.75	1/4-20 UNC x 0.51
2-1/2	UT16DA	F05 / F07	0.55	6.50	3.35	2.76	4.76	3.54	0.75	1/4-20 UNC x 0.51
3	UT21DA	F05 / F07	0.67	6.97	3.78	3.39	5.63	4.41	0.91	5/16-18 UNC x 0.51
4	UT21DA	F05 / F07	0.67	6.97	3.78	3.39	5.63	4.41	0.91	5/16-18 UNC x 0.51
5	UT26DA	F05 / F07	0.67	9.41	3.78	3.39	5.63	4.41	0.91	5/16-18 UNC x 0.51
6	UT31DA	F05 / F07	0.67	9.06	4.45	4.09	6.38	5.16	0.91	5/16-18 UNC x 0.51
8	UT36DA	F07 / F10	0.87	9.69	5.43	5.16	7.72	6.50	1.18	3/8-16 UNC x 0.71
10	UT51DA	F10 / F12	1.06	14.21	7.28	7.17	9.76	8.54	1.46	1/2-13 UNC x 0.79
12	UT51DA	F10 / F12	1.06	14.21	7.28	7.17	9.76	8.54	1.46	1/2-13 UNC x 0.79

DIMENSIONS (inches)

Valve Size	Spring Return Model	ISO	CH	L	W	W2	H	H2	I	B
1-1/2	UT21S5	F05 / F07	0.67	6.97	3.78	3.39	5.63	4.41	0.91	5/16-18 UNC x 0.51
2	UT26S4	F05 / F07	0.67	9.41	3.78	3.39	5.63	4.41	0.91	5/16-18 UNC x 0.51
2-1/2	UT26S4	F05 / F07	0.67	9.41	3.78	3.39	5.63	4.41	0.91	5/16-18 UNC x 0.51
3	UT31S4	F05 / F07	0.67	9.06	4.45	4.09	6.38	5.16	0.91	5/16-18 UNC x 0.51
4	UT36S4	F07 / F10	0.87	9.69	5.43	5.16	7.72	6.50	1.18	3/8-16 UNC x 0.71
5	UT41S4	F07 / F10	0.87	11.42	5.43	5.16	7.72	6.50	1.18	3/8-16 UNC x 0.71
6	UT46S4	F07 / F10	0.87	13.82	5.95	5.75	8.19	6.97	1.18	3/8-16 UNC x 0.71
8	UT51S4	F10 / F12	1.06	14.21	7.28	7.17	9.76	8.54	1.46	1/2-13 UNC x 0.79
10	UT61S5	F14	1.42	17.48	9.25	9.13	12.01	10.79	1.97	5/8-11 UNC x 0.98
12	UT61S5	F14	1.42	17.48	9.25	9.13	12.01	10.79	1.97	5/8-11 UNC x 0.98

FE SERIES BUTTERFLY VALVES

Electric Actuator Dimensions



Note: Pneumatic actuator performance is based on 80psi available control air pressure.

Actuator Technical Data

Valve Size (inches)	Double Acting Pneumatic	Spring Return Pneumatic	Electric
1-1/2	UT16DA	UT21S5	VB015
2	UT16DA	UT26S4	VB030
2-1/2	UT16DA	UT26S4	VB030
3	UT21DA	UT31S4	VB060
4	UT21DA	UT36S4	VB060
5	UT26DA	UT41S4	VB110
6	UT31DA	UT46S4	VB110
8	UT36DA	UT51S4	VB190
10	UT51DA	UT61S5	-
12	UT51DA	UT61S5	-

Pneumatic Actuator Torque Data

Valve Size (inches)	DOUBLE ACTING		SPRING RETURN					
	Model	Torque (in-lbs)	Model	Spring Set (standard)	Spring Torque (in-lbs) Start	Spring Torque (in-lbs) End	Air Torque (in-lbs) Start	Air Torque (in-lbs) End
1-1/2	UT16DA	275	UT21S5	S5	307	230	270	193
2	UT16DA	275	UT26S4	S4	392	247	503	358
2-1/2	UT16DA	275	UT26S4	S4	392	247	503	358
3	UT21DA	500	UT31S4	S4	502	374	626	498
4	UT21DA	500	UT36S4	S4	824	614	986	776
5	UT26DA	750	UT41S4	S4	1011	741	1259	989
6	UT31DA	1000	UT46S4	S4	1779	1120	2005	1346
8	UT36DA	1600	UT51S4	S4	2203	1738	2762	2297
10	UT51DA	4500	UT61S5	S5	5366	4277	4823	3734
12	UT51DA	4500	UT61S5	S5	5366	4277	4823	3734

Pneumatic Actuator Weights and Air Consumption

Valve Size (inches)	DOUBLE ACTING			SPRING RETURN		
	Model	Weight (lbs)	Air Cons. (in ³)	Model	Weight (lbs)	Air Cons. (in ³)
1-1/2	UT16DA	4.03	25.6	UT21S5	7.16	18.1
2	UT16DA	4.03	25.6	UT26S4	9.88	30.0
2-1/2	UT16DA	4.03	25.6	UT26S4	9.88	30.0
3	UT21DA	6.33	44.4	UT31S4	12.28	40.6
4	UT21DA	6.33	44.4	UT36S4	19.88	75.0
5	UT26DA	8.82	68.7	UT41S4	23.61	100.0
6	UT31DA	10.67	88.9	UT46S4	33.11	115.6
8	UT36DA	16.71	153.1	UT51S4	49.89	181.3
10	UT51DA	39.24	425.0	UT61S5	101.19	343.8
12	UT51DA	39.24	425.0	UT61S5	101.19	343.8

FE SERIES BUTTERFLY VALVES

Electrical Actuator

Model VB015

Models VB030, VB060, VB110, VB190

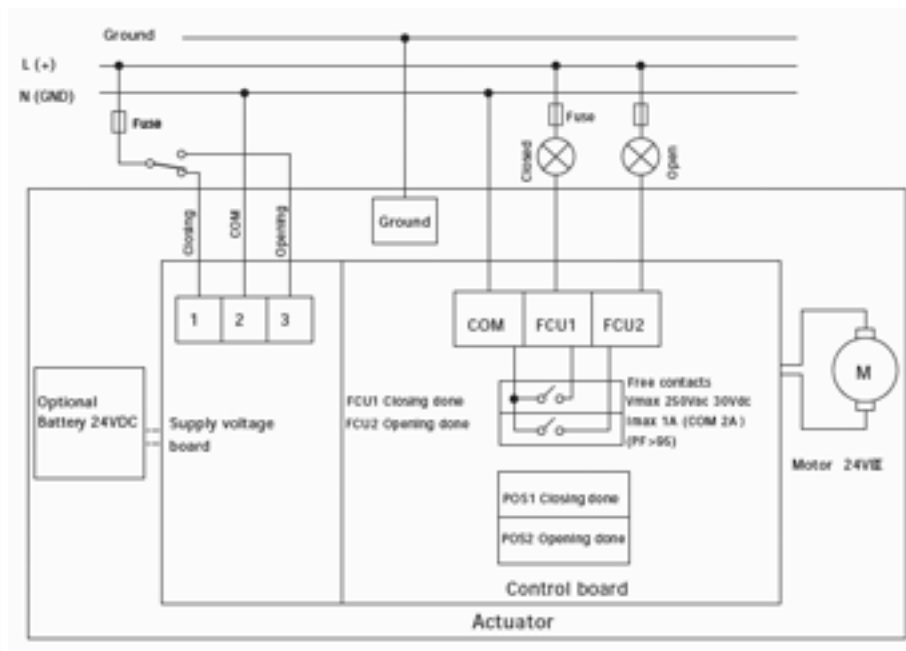
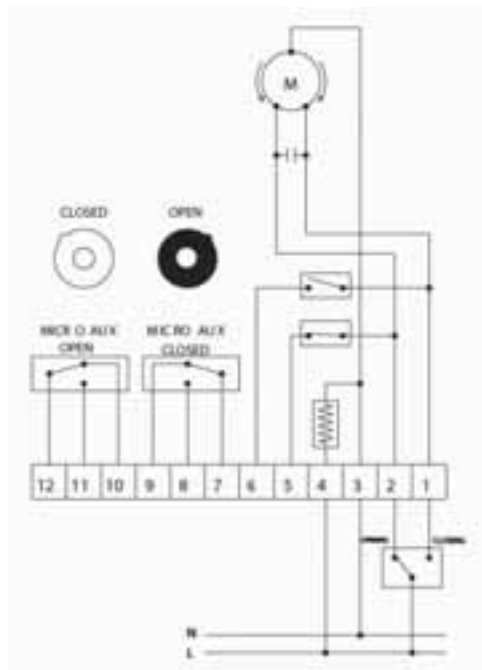

ELECTRICAL ACTUATOR DATA

Model	VB015	VB030	VB060	VB110	VB190
1 Maximum Working Torque (in-lbs)	133	266	530	975	1680
2 Voltage	110 VAC	100-240 VAC	100-240 VAC	100-240 VAC	100-240 VAC
3 Absorbed Current	50 mA	0.3-0.2 A	0.6-0.3 A	0.6-0.3 A	0.6-0.3 A
4 Absorbed Power	6.6 VA	30-48 VA	60-72 VA	60-72 VA	60-72 VA
5 Working Time	25 sec	8 sec	9 sec	27 sec	27 sec
6 Torque Limiter	STD	STD	STD	STD	STD
7 Duty Rating	50%	75%	75%	75%	75%
8 Protection	IP 65-67	IP 65-67	IP 65-67	IP 65-67	IP 65-67
9 Rotation	90°	90°	90°	90°	90°
10 Manual Override	STD	STD	STD	STD	STD
11 Position Indicator	STD	STD	STD	STD	STD
12 Working Temperature	-4°F / +131°F	-4°F / +131°F	-4°F / +131°F	-4°F / +131°F	-4°F / +131°F
13 Heater	STD	STD	STD	STD	STD
14 Additional Limit Switches	2 STD	2 STD	2 STD	2 STD	2 STD
15 ISO 5211 Mounting	F03 F05	F03 F05	F05 F07	F07 F10	F07-F10
16 Square (in)	0.43	0.43	0.55	0.67	0.87
17 Electrical Connections	PG11	PG11	PG11	PG11	PG11
18 Weight (lbs)	3.09	5.07	7.28	10.80	10.80

FE SERIES BUTTERFLY VALVES

Components (cont'd)

Sizes 10" to 12"

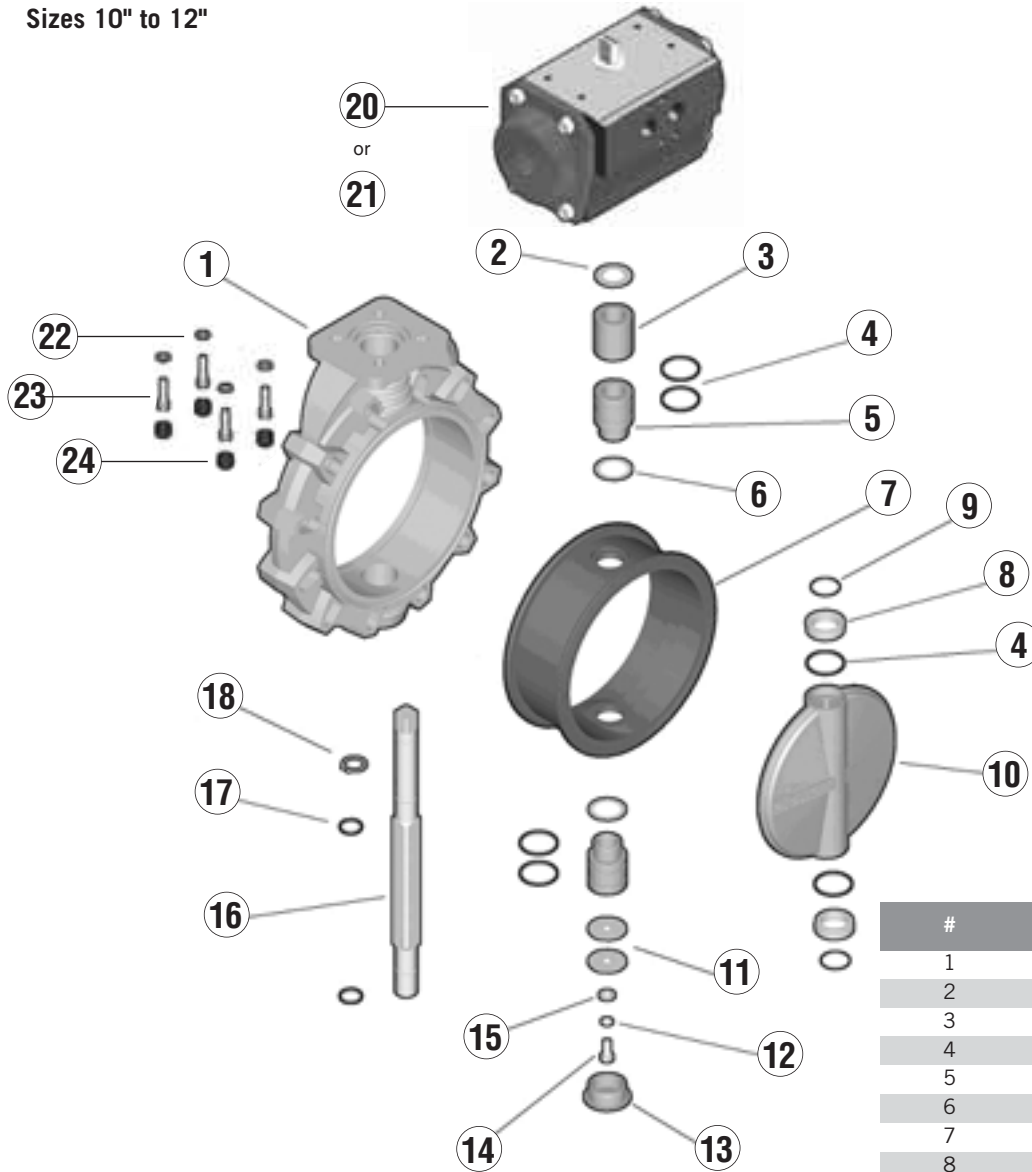

#	Component
1	Body
2	Washer
3	Bushing
4	Bushing O-Ring
5	Bushing for O-Ring
6	Washer
7	Primary Liner
8	Anti-Friction Ring
9	Disc O-Ring
10	Disc
11	Washer
12	Washer
13	Cap
14	Screw
15	Washer
16	Shaft
17	Shaft O-Ring
18	Retaining Ring
19	O-Ring
20	Pneumatic Actuator
21	Electric Actuator (not shown)
22	Washer
23	Screws
24	Protection Cap

FE SERIES BUTTERFLY VALVES

Installation Procedures

1. Ensure that the length of the bolts is sufficient for the size of valve being installed. Due to the varying designs of plastic flanges, there is no recommended minimum length. However, a length that results in at least 5 exposed threads on each side should be sufficient.

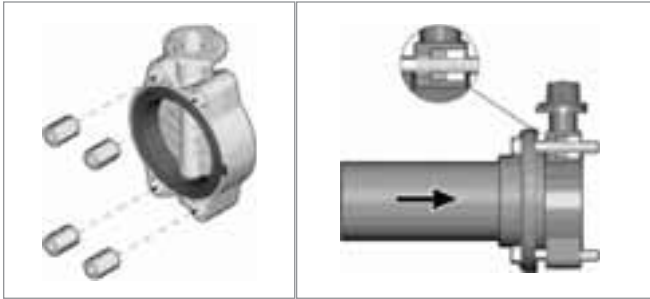

2. Please refer to the appropriate application sub-section:
 - a. For typical inline installation, ensure that the disc is in the partially closed position then carefully insert the valve into the piping system between the two flanges. Insert the bolts, washers, and nuts (if necessary), then hand tighten. Take care to properly line up the valve and flanges as any misalignment may cause leakage.
 - b. For lugged version end of line installation, insert the necessary steel lugs into the valve body. Ensure that the disc is in the partially closed position then carefully position the valve on the flange. Insert the bolts, and washers, then hand tighten. Take care to properly line up the valve and flange as any misalignment may cause leakage.
3. Connect pneumatic or electric connections according to provided diagrams.
4. To avoid damage to the primary gasket, cycle the valve to the open position before tightening the bolts. For correct joining procedure, please refer to the section entitled, "Joining Methods – Flanging" in the IPEX Industrial Technical Manual Series, "Volume I: Vinyl Process Piping Systems". The bolts should be tightened in an even pattern to the nominal torque in the table below. These torque ratings are sufficient to maintain a watertight seal at the maximum rated operating pressure.

Note: End of line installation will cause the maximum rated pressure to be reduced to the values listed in the table below. If the process media is dirty or contains suspended particles, it is advisable to install the valve in an orientation in which the shaft is not vertical (see diagrams). Over time, particles may collect at the bottom of the valve posing a threat to the seal between the disc, liner, and shaft. 0° normal service 45° dirty fluids 90° suspended particles

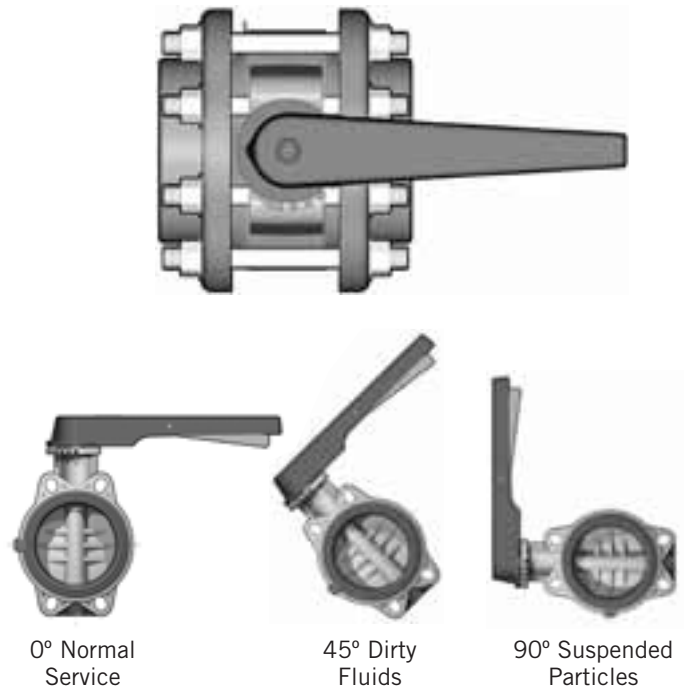

Size (inches)	Nominal Bolt Torque (ft-lbs)	Lugged Pmax (psi)
1-1/2	7	90
2	9	90
2-1/2	11	90
3	13	90
4	15	90
5	26	90
6	30	60
8	41	60
10	52	-
12	52	-

FE SERIES BUTTERFLY VALVES

Valve Maintenance

Disassembly

1. If removing the valve from an operating system, isolate the valve from the rest of the system. Be sure to depressurize and drain the isolated branch before continuing. It is recommended that all actuators be de-activated before servicing the valve to avoid injury
2. Cycle the valve to a partially open position then loosen each bolt holding the valve to the pipe flange(s). Please refer to the section entitled, "Joining Methods – Flanging" in the IPEX Industrial Technical Manual Series, "Volume I: Vinyl Process Piping Systems" for a recommended bolt tightening pattern diagram. Follow the same pattern when disassembling the flanged joint(s) then carefully remove the valve from the line.

Sizes 1-1/2" to 8":

4. Loosen and remove the bolts, washers and protection caps fixed to the actuator (2, 3 & 4). Carefully remove the actuator from the valve taking care not to damage the stem.
5. Remove the cap (18) then loosen and remove the screw (17) and washer(s) (16) from the base of the valve body.
6. Carefully pull the shaft (5) out of the valve body then remove the disc (14).
7. Remove the primary liner (15) from the valve body.
8. Remove the nylon bushing (10) and o-rings (9) from the valve body (sizes 2-1/2" to 8").
9. Remove the disc anti-friction rings (13), and o-rings (12, sizes 2-1/2" to 8").
10. Remove the retaining ring (8, sizes 2-1/2" to 8") and orings (6, 7) from the shaft.
11. The valve components can now be checked for problems and/or replaced.

Sizes 10" to 12":

3. Loosen and remove the bolts, washers and protection caps fixed to the actuator (22, 23 & 24). Carefully remove the actuator from the valve taking care not to damage the stem.
4. Remove the cap (13) then loosen and remove the screw (14) and washers (11, 12, and 15) from the base of the valve body (1).
5. Carefully pull the shaft (16) out of the valve body then remove the disc (10).
6. Remove the primary liner (7) from the valve body
7. Remove the upper and lower bushings (3, 5), washers (2, 6), and o-rings (4) from the valve body.
8. Remove the disc anti-friction rings (8) and o-rings (4, 9).
9. Remove the retaining ring (18) and o-rings (17) from the shaft.
10. The valve components can now be checked for problems and/or replaced.

FE SERIES BUTTERFLY VALVES

Assembly

Note: Before assembling the valve components, it is advisable to lubricate the o-rings with a water soluble lubricant. Be sure to consult the "IPEX Chemical Resistance Guide" and/or other trusted resources to determine specific lubricant-rubber compatibilities.

Sizes 1-1/2" to 8":

1. Insert the primary liner (15) into the valve body (11). Ensure that the proper holes line up with those on the body.
2. Properly fit the o-rings (9) on the nylon bushing (10) (sizes 2-1/2" to 8") then insert into the valve body from above.
3. Properly fit the disc o-rings (12, sizes 2-1/2" to 8") and anti-friction rings (13) on the disc (14), then insert into the valve liner taking care to center the holes.
4. Properly fit the o-rings (6, 7) and retaining ring (8, sizes 2-1/2" to 8") in their grooves on the shaft (6), then carefully insert into the valve body from above.
5. Fasten the shaft at the base of the valve body using the screw (17) and washer (16). Affix the cap (18) over the bolt.
6. For 8" sizes, affix the spacer pad (20) to the valve body using the screws (19), washers (21), and nuts (22).
7. Carefully place the actuator on the stem, lining up the holes. Fasten using the necessary bolts, washers and protective caps (2, 3 & 4). Ensure that the actuator and disk position correspond to the same operating position.

Sizes 10" to 12":

1. Insert the primary liner (7) into the valve body (1). Ensure that the proper holes line up with those on the body.
2. Properly fit the o-rings (4) on the upper and lower bushings (3, 5) then insert into the valve body from above and below along with the washers (2, 6).
3. Properly fit the disc o-rings (4, 9) and anti-friction rings (8) on the disc (10), then insert into the valve liner taking care to center the holes.
4. Properly fit the o-rings (17) and retaining ring (18) in their grooves on the shaft (16), then carefully insert into the valve body from above.
5. Fasten the shaft at the base of the valve body using the screw (14) and washers (11, 12, and 15). Affix the cap (13) over the bolt.
6. Carefully place the actuator on the stem, lining up the holes. Fasten using the necessary bolts, washers and protection caps (22, 23 & 24). Ensure that the actuator and disk position correspond to the same operating position.

This page intentionally
left blank

SECTION SIX: ACCESSORIES

OVERVIEW

All modern pneumatic actuators offer an array of accessories such as position indicators, manual over rides, limit switch boxes (with or without indicators), speed controls and pneumatic or electronic positioners. These items are described in details in the following section.

Solenoid

- Universal Application 3-way or 4-way selectable with a simple field interchangeable insert
- Inlet and Exhaust port sizes are 1/4" NPT
- Manual Override Standard
- NEMA 4 Class H Coil Standard on each unit
- Additional protection classes available; Intrinsically Safe and Explosion Proof (NEMA 7/9)
- All units are stamped with a progressive traceable serial number



Standard Voltage	24 – 110 -220V; 50/60 Hz; 12 – 24V DC
Duty Cycle	100%
Protection Class	NEMA 4, 4x with connector assembled
Air Supply Connection	1/4" NPT
Operating Pressure	30psi – 145psi
Din Connector	1/2" NPT
Flow Factor	Cv 0.5
Operating Temperature	-4F to 158F
Weight	1.08lb

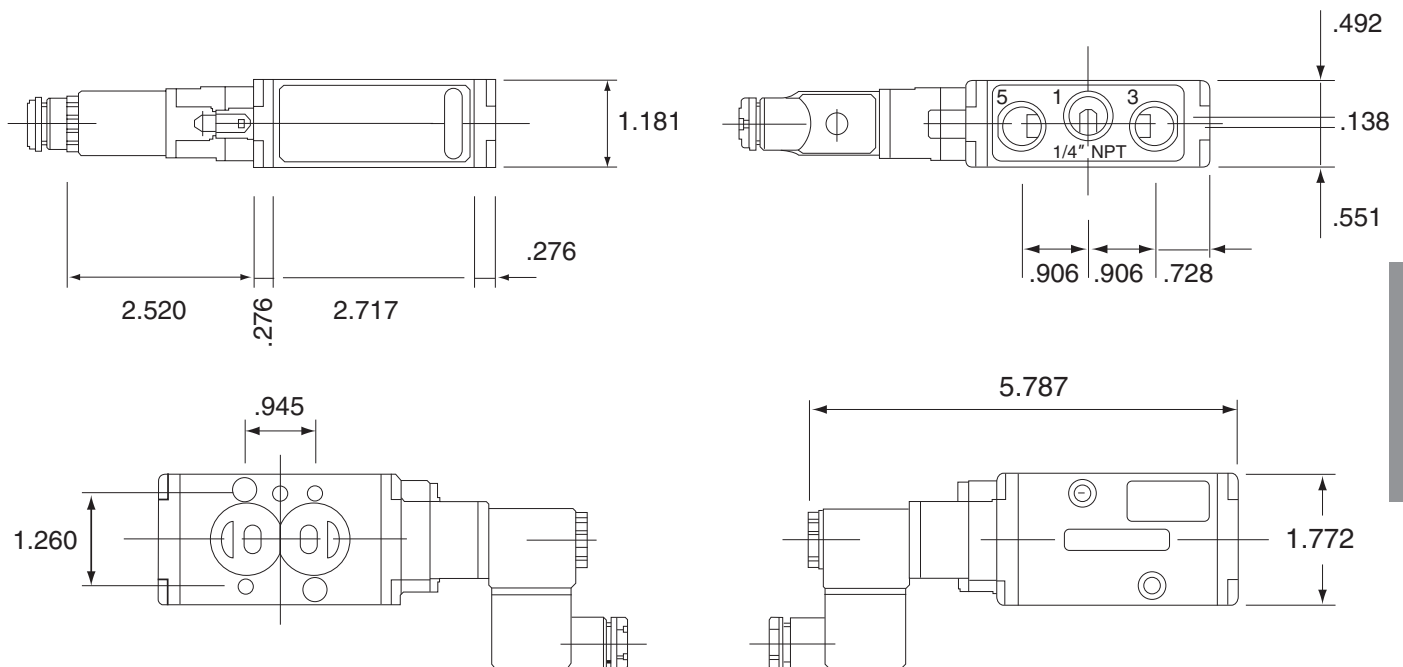

ACCESSORIES

Speed Control

Provide infinite variation of control of air flow at an acceptable sound level on the exhaust ports of air valves with complete safety. An external adjustment screw accurately varies orifice opening from closed to full flow as required. The final position is then locked into place by a lock nut mechanism. Objectionable exhaust air noise is eliminated by the surrounding sleeve of sintered bronze.

Exhaust Filter



Utilize porous sintered bronze filter element secured to Brass pipe fittings. They are used to diffuse air and muffle noise from the exhaust ports of air valves to an acceptable level within OSHA noise requirements. These mufflers can also be used as filters, preventing corrosive atmosphere from entering the actuator thus extending the actuators working life.

Limit Switch Box

Manufactured completely in techno-polymer with stainless steel fasteners and Nema 4, 4x rating, these products are corrosion resistant and suitable for the most corrosive environments.

The operating position of the switches can be easily changed by adjusting the high resolution spline cams manually and independently with the need for additional tools. The cams are spring backed and will not be affected by normal vibration.

Each box is equipped with two (2) standard 1/2" NPT conduit entries and one (1) terminal strip with 8 contact points.

Comes standard with a high visibility beacon, offering clear location of the current valve position.

The switchbox also comes standard with stainless steel captive cover bolts; an added feature to ensure long life of the switchbox.



SPDT Mechanical Switches

With 8 Point Terminal Strip on a printed circuit board



Technical Data

Operating Force	0.135 lbf (0.60 N)
Release Force	0.014 lbf (0.06 N)
Differential Travel	0.189 in (4.8 mm)
Over-travel	0.032 in (0.8 mm)

Electrical Rating

Contact Arrangement: SPDT (Form C)

Rated Voltage	Resistive Load	Inductive Load
125 VAC	5 Amp	3 Amp
250 VAC	3 Amp	2 Amp
8 VDC	5Amp	5 Amp
14 VDC	5 Amp	4 Amp
30 VDC	4 Amp	3 Amp
125 VDC	0.4 Amp	0.4 Amp
250 VDC	0.2 Amp	0.2 Amp

Wiring Diagram

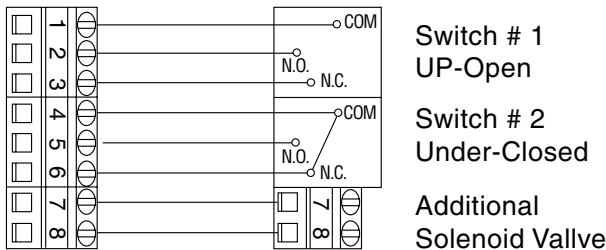

Materials

Box	Technopolymer
Brackets	Technopolymer
Position Indicator	Technopolymer
Fasteners	Stainless Steel
Seals	Buna-N
Operating Shafts	Technopolymer
Cams	Technopolymer
Microswitches	Technopolymer
Electrical Board with Clamps	Polyamide

Inductive Proximity Sensors



Nominal voltage	8V
Current consumption	
Sensing face covered	1mA
Sensing face free	3mA
Switching frequency	1000Hz
Self inductance	50mH
Self capacitance	35nF
Protection	IP67
Operating Temperature	-25 to 100°C

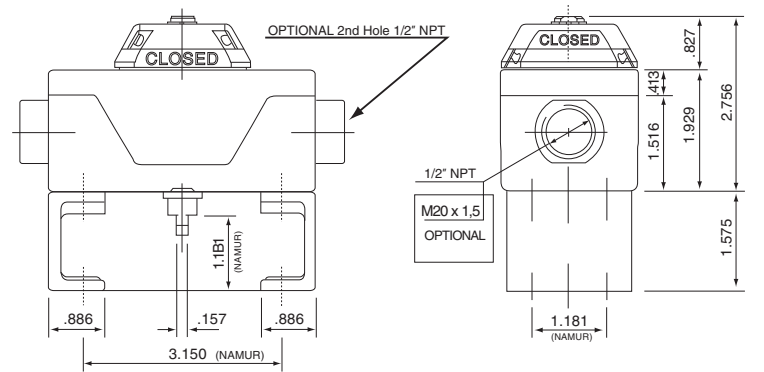

DIRECT ASSEMBLY WITH UT11 /14 /19

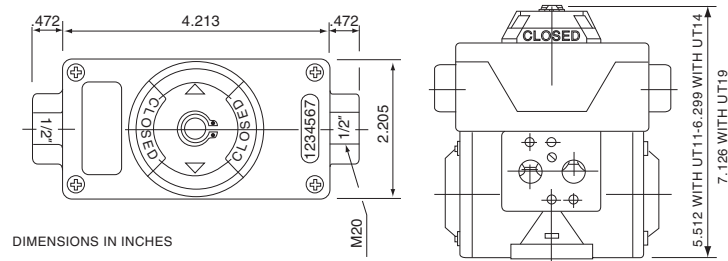

DIMENSIONS IN INCHES

Positioners

Electro-Pneumatic General Information

The electro-pneumatic positioner is used for rotary operation of pneumatic rotary valve actuators by means of an electrical controller or control system with an analog output signal of 4 to 20 mA or split ranges.

Features

- No resonance in the range of 5~200Hz.
- 1/2 Split Control without any other substitutes.
- Easy to adjust zero and span.
- Easy to convert from Reverse Action to Direct Action or vice versa.
- Easy Feedback Connection.
- Fast and accurate response.
- Low air consumption.
- Easy to protect from hunting effect by using output orifice for small size actuators.
- Designed as a block build structure for maintenance and repair.

Specifications

Input Signal	4 to 20mA DC
Impedance	250 + 15
Supply Pressure	0.14 to 0.7 Mpa
Stroke	0° to 90°
Air connection	1/4" NPT
Gauge Connection	1/8" NPT
Degree of Protection	IP66
Operating Temperature	4F to 150F (-20C to 70C)
Linearity	+ 2%
Sensitivity	0.50%
Repeatability	0.50%
Air Consumption	0.18 CFM
Flow Capacity	2.83 CFM
Material	Die-cast Aluminum
Weight	2.8Kg with junction box



Options

- Electro-pneumatic positioner with limit switch and beacon.
- Electro-pneumatic positioner with position transmitter.
- Electro-pneumatic positioner with limit switch, beacon and position transmitter (shown above).

Positioners

Pneumatic General Information

The pneumatic positioner is used for rotary operation of pneumatic rotary valve actuators by means of a pneumatic controller or control system with an output signal of 3-15psi.

Specifications

Input Signal	0.2 – 1.0 kgf/cm ² (3 – 15 psi)
Supply Pressure	1.4 – 7.0 kgf/cm ² (20 – 100 psi)
Stroke	0° to 90°
Connection	PT 1/4" (Gauge PT 1/8) NPT 1/4" (Gauge NPT 1/8)
Pressure Gauge	0-28psi, 0-57psi, 0-140psi
Ambient Temperature	-22°F to 185°F
Linearity	±2% F.S
Hysteresis	±1% F.S
Sensitivity	±0.5% F.S
Repeatability	±0.5% F.S
Air Consumption	0.11 CFM, (Sup. = 20psi)
Max. Flow Capacity	2.8 CFM, (Sup. = 20psi)
Weight	1.7kg (3.7lb)
Material	Aluminum Diecasting



Options

- Pneumatic positioner with limit switch and beacon.
- Pneumatic positioner with position transmitter.
- Pneumatic positioner with limit switch, beacon and position transmitter.

This page intentionally
left blank

SECTION SEVEN: STANDARDS

OVERVIEW

Standards exist to ensure that thermoplastic piping systems meet the required level of performance for a particular application. IPEX engineers and technical staff actively participate in thermoplastic standards development throughout North America. These activities result in new standards and improvements to existing standards for thermoplastic piping.

Standards Organizations

IPEX products comply with standards developed by several standards organizations. Additional information on standards and compliance can be obtained by contacting the following organizations.

ASTM International, www.astm.org
100 Barr Harbor Drive, West Conshohocken, Pennsylvania USA 19428-2959

ANSI, www.ansi.org
1819 L Street, NW., Suite 600, Washington DC USA 20036

ISO, www.iso.org
1 rue de Varembé, Case postale 56, CH-1211 Geneva 20, Switzerland

NSF International, www.nsf.org
P.O. Box 130140, 789 N. Dixboro Rd, Ann Arbor, Michigan USA 48113-0140

Applicable Standards

The following is a list of applicable standards for IPEX thermoplastic valves and related piping systems. This list is up-to-date at the time of printing.

ASTM

D1784	Standard Specification for Rigid Poly(Vinyl Chloride) (PVC) Compounds and Chlorinated Poly(Vinyl Chloride) (CPVC) Compounds
D1785	Standard Specification for Poly(Vinyl Chloride) (PVC) Plastic Pipe, Schedules 40, 80, and 120
D2464	Standard Specification for Threaded Poly(Vinyl Chloride) (PVC) Plastic Pipe Fittings, Schedule 80
D2466	Standard Specification for Poly(Vinyl Chloride) (PVC) Plastic Pipe Fittings, Schedule 40
D2467	Standard Specification for Poly(Vinyl Chloride) (PVC) Plastic Pipe Fittings, Schedule 80
D3222	Standard Specification for Unmodified Poly(Vinylidene Fluoride) (PVDF) Molding Extrusion and Coating Materials
D4101	Standard Specification for Polypropylene Injection and Extrusion Materials
F437	Standard Specification for Threaded Chlorinated Poly(Vinyl Chloride) (CPVC) Plastic Pipe Fittings, Schedule 80
F439	Standard Specification for Chlorinated Poly(Vinyl Chloride) (CPVC) Plastic Pipe Fittings, Schedule 80
F441/F441M	Standard Specification for Chlorinated Poly(Vinyl Chloride) (CPVC) Plastic Pipe, Schedules 40 and 80
F1498	Standard Specification for Taper Pipe Threads 60° for Thermoplastic Pipe and Fittings

ANSI

- | | |
|---------|-----------------------------------|
| B1.20.1 | Pipe Threads, General Purpose |
| B16.5 | Pipe Flanges and Flanged Fittings |

ISO

- | | |
|---------|---|
| 10931 | Plastics piping systems for industrial applications - Poly(vinylidene fluoride) (PVDF) - Specifications for components and the system |
| 11922-1 | Thermoplastics pipes for the conveyance of fluids - Dimensions and tolerances - Part 1: Metric series |

NSF

- | | |
|--------|--|
| NSF 14 | Plastic Piping System Components and Related Materials |
| NSF 61 | Drinking Water System Components - Health Effects |

SALES AND CUSTOMER SERVICE

Canadian Customers call IPEX Inc.

Toll free: (866) 473-9462

www.ipexinc.com

U.S. Customers call IPEX USA LLC

Toll free: (800) 463-9572

www.ipexamerica.com

About the IPEX Group of Companies

As leading suppliers of thermoplastic piping systems, the IPEX Group of Companies provides our customers with some of the largest and most comprehensive product lines. All IPEX products are backed by more than 50 years of experience. With state-of-the-art manufacturing facilities and distribution centers across North America, we have established a reputation for product innovation, quality, end-user focus and performance.

Markets served by IPEX group products are:

- Electrical systems
- Telecommunications and utility piping systems
- PVC, CPVC, PP, ABS, PEX, FR-PVDF and PE pipe and fittings (1/4" to 48")
- Industrial process piping systems
- Municipal pressure and gravity piping systems
- Plumbing and mechanical piping systems
- PE Electrofusion systems for gas and water
- Industrial, plumbing and electrical cements
- Irrigation systems

Products manufactured by IPEX Inc. and distributed in the United States by IPEX USA LLC.

This literature is published in good faith and is believed to be reliable. However, it does not represent and/or warrant in any manner the information and suggestions contained in this brochure. Data presented is the result of laboratory tests and field experience.

A policy of ongoing product improvement is maintained. This may result in modifications of features and/or specifications without notice.

